



Gujarat National Law University

STANDARD BIDDING DOCUMENT PROCUREMENT OF CIVIL WORKS

GUJARAT NATIONAL LAW UNIVERSITY

**COMPLETE BIDDING DOCUMENT FOR PROVIDING
AND FIXING CHAINLINK FENCING AROUND
FOOTBALL GROUND, PUNIT VAN AND ACEDIMIC
BLOCK**

Index

<u>Sr No</u>	<u>Section</u>	<u>Description</u>	<u>Page No</u>
1		Invitation for Bid (IFB)	3-5
2	Section -1	Instructions to Bidders	6-26
3	Section -2	Qualification Information	27-34
4	Section -3	Conditions of Contract	35-63
5	Section -4	Contract Data	64-73
6	Section -5	Technical Specification	74-84
7	Section -6	Form of Bid	85-88
8	Section -7	Bill of Quantities	89-92
9	Section -8	Securities and Other Forms	93-104
10	Section -9	Drawings	105-106
11	Section -10	Documents to be furnished by Bidder	107-108

INSTRUCTIONS TO BIDDERS

(ITB)

1	Tender Notice No.	PC-10/2024
2	Tender Inviting Authority	Registrar, Gujarat National Law University
3	Name of the Project	Tender for Providing and Fixing Chain link fencing around Football ground, Punit Van and Academic Building.
4	Start of Issuance of Tender	Start of Issuance of Tender 15/02/2025 on https://tender.nprocure.com/
5	Last Date for online Submission of Technical and Financial bid	10/03/2025 up to 5:00 pm on https://tender.nprocure.com/
6	Last Date and Time for Submission of Tender fee, EMD and Physical copy of Technical bid document	17/03/2025 up to 5:00 pm
7	Opening of Primary Stage at GNLU, Gandhinagar	18/03/2025 at 11:00 am
8	Date and time for opening of financial bid	Will be intimated to eligible bidders
9	Place for submission of the bid proposal, the opening of technical & financial bid and Comprehensive Demo	Gujarat National Law University, Attalika Avenue, Knowledge Corridor, Koba - 382426, Gandhinagar, Gujarat

NATIONAL COMPETITIVE BIDDING

1. Registrar Gujarat National Law University, Gandhinagar invites bids for the works detailed in the table.

The bidders may submit bids for any or all of the following works.

1. TABLE

Sr. No.	Name of work	Approximate value of works (Rs.)	Bid security (Rs.)	Cost of document (Rs.)	Period of completion	#Class of Registration / Category of contractor if required
1	2	3	4	5	6	7
1	Providing and fixing Chain link fencing around Football ground, Punit Van and Academic building	37,02,500/-	37250/-	Rs.1500/- + Rs.270/- (18% GST) =Rs.1770/-	06 Months	Class-B" and above

2. Prospective / Interested bidder may download the Bid Documents from website <https://tender.nprocure.com/> free of cost till the Time and Date as mentioned on online NIT at website on <https://tender.nprocure.com/>
- (A) The concerned Contractor/bidder shall submit the certificate of registration or renewal receipt as approved contractor in n class in "B" Class in NWRWS & K Dept / SSNNL/ R & B Dept of Gujarat State or equivalent class in CPWD/ Railway /other State Government.
3. However, Bidder who is submitting the Bid Online will have to pay the Bid Document Fee / Tender Fee through Demand Draft only of any Schedule Bank payable at Gandhinagar and in favour of 'Registrar Gujarat National Law University, Gandhinagar'. Once the Bid is received online, Bid Document / Tender Fee will not be refundable.
- The Demand Draft for Bid Document / Tender fee and FDR / Bank Guarantee against Bid Security / EMD shall be submitted in electronic format through online (by scanning) while uploading the bid, this submission shall mean that bid document / tender fee and Bid Security / EMD has been received. Accordingly, the offer of only those shall be opened whose Bid Document / Tender Fee and Bid Security / EMD have been received electronically. However, for the purpose of realization of Demand Draft, and FDR / Bank Guarantee bidder shall send the same in original through R.P.A.D./Speed Post/Courier so as to reach to Registrar Gujarat National Law University, Attalika Avenue, Knowledge corridor, Koba, Gandhinagar' within 07 days from the last day of bid submission.
- Penetrative action for not submitting Demand Draft / FDR / Bank Guarantee in original to Tender Inviting Authority by bidder shall be initiated.
4. Bids received online, will be opened on the time, date and place as specified in the online NIT at website https://tender.nprocure.com the presence of the bidders or their authorized representatives, who wish to remain present.
- If the office happens to be closed on the day of opening of the bids as specified, the bids will be opened on the next working day at the same time and venue.
5. Deleted

6. Bid Security (EMD) is equal to 1% of Estimated Amount put to bid / tender and should be rounded off to the next thousand rupees. (The validity of EMD should be 165 days from the date of uploading of B.G. /FDR documents on n-code.).
 7. Other Information is as under:
 - A. Agencies can prepare and edit their offers a number of times before the end of the tender submission date and time. After the tender submission date and time, the bidder cannot modify / edit / withdraw their submitted offer in any case. No written or online request in this regard shall be granted.
 - B. Offers in physical form will not be accepted in any case.
 - C. Demand Draft purchased by the other than bidder and issued after the last date of submission of Bids, will not be considered or accepted.
 - D. The cost incurred by the contractor for this offer for clarification or attending discussion, conferences or site visits will not be reimbursed by the Employer or Engineer-in-Charge.
 - E. Conditional tender shall not be accepted.
 - F. Any changes, addition, alternation made in the prescribed form attached with tender are liable to be rejected.
 - G. Any change in format or conditional Bank Guarantee will not be accepted and the bidder will be considered non-responsive.
 - H. All the bidders are instructed to fill in information strictly in accordance with the format given in the checklist /qualification document / tender document.
 - I. It is mandatory for the bidders to supply each and every information as asked strictly in electronic format at appropriate places only.
 - J. Blank / insufficient information shall be treated as nil information and shall result in disqualification.
 - K. Even if the bidder has been qualified in a similar or larger size of project in the past, it shall not be deemed to be a ground / reason for not giving required information for this work / bid.
 - L. Information supplied for earlier projects shall not be considered while evaluation of this bid. The Government will not ask for any other information, unless it is found absolutely necessary by the competent authority.
 - M. If found necessary, the contractor will be intimated for negotiation,
For the works costing under Rs. 7.5 crore for Construction work of Water Resources Department, Rs. 7.0 crore for Roads, Bridges and Building and Rs. 050 crore for Electrical work following documents shall be submitted in electronic format only through online by scanning and the (i) Bid Document Fee / Tender Fee (ii) Bid Security / EMD should be sent in original to the Tender opening authority through RPAD/ Courier / Speed Post only so as to reach Registrar Gujarat National Law University, Attalika Avenue, Knowledge corridor, Koba, Gandhinagar within 7 days from last day of submission of Bid.
1. Scanned copy of DD of Tender Fee (of amount as prescribed in tender notice)
 2. Scanned copy of Bid Security / EMD Exemption Certificate as per Clause No.16 of Section-1 (b) (of amount as prescribed in tender notice).
 3. Scanned copy of Valid Registration certificate/renewal receipt of registration fee (for those bidders who are registered in equivalent to class "A and above)" of Gujarat State).
 4. Form of Bid as prescribed in Volume-III, Section-6.

VOLUME-I

SECTION - 1

INSTRUCTIONS TO BIDDERS

(ITB)

Section 1: Instructions to Bidders

Table of Contents

	Page No.		Page No.
A. General		D. Submission of Bids	
1. Scope of Bid	9	19. Sealing & Marking of Bids	18
2. Source of Funds	9	20. Deadline for Submission of Bids	18
3. Eligible Bidders	9	21. Late Bids	18
4. Qualification of the Bidder	9	22. Modification and Withdrawal of Bids	18
5. One Bid per Bidder	10		
6. Cost of Bidding	10	E. Bid Opening and Evaluation	
7. Site Visit	11	23. Bid Opening	19
		24. Process to be Confidential	20
B. Bidding Documents		25. Clarification of Financial Bids	20
8. Content of Bidding Documents	12	26. Examination of Bids and Determination of Responsiveness	20
9. Clarification of Bidding Documents	12	27. Correction of Errors	20
10. Amendment of Bidding Documents	12	28. Deleted	21
		29. Evaluation and Comparison of Financial Bids	21
C. Preparation of Bids		30. Deleted	21
11. Language of Bid	13		
12. Documents Comprising the Bid	14	F. Award of Contract	
13. Bid Prices	14	31. Award Criteria	22
14. Currencies of Bid and Payment	15	32. Employer's Right to Accept any Bid and to Reject any or all Bids	22
15. Bid Validity	16	33. Notification of Award and Signing of Agreement	22
16. Bid Security	16	34. Performance Security	22
17. Alternative Proposals By Bidders	17	35. Advance Payment and Security	23
18. Format and Signing of Bid	17	36. Dispute Review Expert	23
		37. Security of Funds	23

A.
GENERAL

1. Scope of Bid

- 1.1 The Employer (Named in Appendix to ITB) invites bids for the Construction of works (as defined in these documents and referred to as ‘the works’) detailed in the table given in IFB. The bidders may submit bids for any or all of the works detailed in the table given in IFB.
- 1.2 The successful bidder will be expected to complete the works by the intended completion date specified in the Contract data.
- 1.3 Throughout these bidding documents, the terms ‘bid’ and ‘tender’ and their derivatives (bidder/ tenderer, bid / tender, bidding/ tendering, etc.) are synonymous.

2. Source of Funds

- 2.1 The expenditure on this project will be met from the budget of Govt. of Gujarat / Govt. of India for centrally sponsored projects.

3. Eligible Bidders

- 3.1 This Invitation for Bids is open to all eligible bidders.
- 3.2 All bidders shall provide in Section 2, Forms of Bid and Qualification Information, a statement that the Bidder is neither associated, nor has been associated, directly or indirectly, with the consultant or any other entity that has prepared the design, specifications, and other documents for the Project or being proposed as Project Manager for the Contract. A firm that has been engaged by the Employer to provide consulting services for the preparation or supervision of the works, and any of its affiliates, shall not be eligible to bid.

4. Qualification of the Bidder

- 4.1 All bidders shall provide in Section 2, Forms of Bid and Qualification Information, a preliminary description of the proposed work method and schedule, including drawings and charts, as necessary. The proposed methodology should include a program of construction backed with equipment planning and deployment duly supported with broad calculations and quality assurance procedures proposed to be adopted justifying their capability of execution and completion of work as per technical specifications, within stipulated period of completion.

4.2 Deleted

4.3 Deleted

4.4 Deleted

4.5 QUALIFICATION CRITERIA: Deleted

4.5.1 Deleted

4.5.2 Base year and Escalation

Deleted

4.5.3. General Experience-Deleted

4.5.5. Equipment Capabilities :Deleted

-

4.5.6. Financial Position

The Applicant should give undertaking that he has access to, or has available, liquid assets (aggregate of working capital, cash in hand and uncommitted bank guarantees) and / or credit facilities up to 25 percent of the value of the contract / contracts applied.

4.5.7. Deleted

4.5.8. Litigation History

The Applicant should provide accurate information on any litigation or arbitration resulting from contracts completed or under execution by him over the last five financial years. A consistent history of awards against the Applicant or any partner of a joint venture may result in failure of the applicant.

4.5.9. Disqualification

Even though the applicants meet the above criteria, they are subject to be disqualified if they have:

Made misleading or false representation in the forms, statements submitted, and / or

Record of poor performance such as abandoning the work, rescinding of contract for which the reasons are attributable to the non – performance of the contractor; consistent history of litigation awarded against the applicant or financial failure due to bankruptcy. The rescinding of contract of a joint venture on account of reasons other than non – performance, such as Most Experienced partner of joint venture pulling out, court directions leading to breaking up of a joint venture before the start of work, which are not attributable to the poor performance of the contractor will, however, not affect the qualification of the individual partners.

**4.6 JOINT VENTURE: (Maximum 3 Members i.e. 1 Lead & 2 Others)
(Not Applicable)**

4.7. Bid Capacity. Deleted

4.8 Even though the bidders meet the above qualifying criteria, they are subject to be disqualified if they have:

- Made misleading or false representation in the forms, statements and Attachments the submitted in proof the qualification requirements; and / or
Record of poor performance such as abandoning the works, not properly completing the contract, inordinate delay in completion, litigation history, or financial failures etc.; and/ or
- Participated in the previous bidding for the same work and had quoted unreasonably high bid prices and could not furnish rational justification to the employer.

5. One bid per bidder

5.1. Each bidder shall submit only one bid for one package. A bidder who submits or participates in more than one bid (other than as a subcontractor or in cases of alternatives that have been permitted or requested) will cause all the proposals with the bidder's participation to be disqualified.

6. Cost of Bidding

6.1. The bidder shall bear all costs associated with the preparation and submission of his Bid, and the Employer will in no case be responsible and liable for those costs.

7. Site Visit

7.1. The Bidder, at the Bidder's own responsibility and risk is encouraged to visit and examine the Site of work and its surrounding and obtain all information that may be necessary for preparing the Bid and entering into a contract for construction of the Works.

The costs of visiting the site shall be at the Bidder's own expense.

B. BIDDING DOCUMENTS

8. Content of Bidding Documents

8.1 The set of bidding documents comprises the documents listed below and addenda issued in accordance with Clause 10:

Section	Particulars	Volume No.
-	Invitation for Bids	I
1	Instructions to Bidders	
2	Qualification Information, and other forms	
3	Conditions of Contract	
4	Contract Data	
5	Technical Specifications	II
6	Form of Bid	III
7	Bill of Quantities	
8	Securities and other forms	
9	Drawings	IV
10	Documents to be furnished by bidder	V

8.2. Volumes I, II, III and IV are available online and documents to be furnished by the bidder in compliance to section 2 will be prepared by him and furnished as Volume- V in two parts (refer clause 12).

8.3. The bidder is expected to examine carefully all instructions, conditions of contract, contract data, forms, terms, and technical specifications, bill of quantities, forms, Annexes and drawings in the Bid Document. Failure to comply with the requirements of Bid Documents shall be at the bidder's own risk. **Pursuant to clause 26 hereof**, bids which are not substantially responsive to the requirements of the Bid Documents shall be rejected.

9. Clarification Bidding Documents

9.1 A prospective bidder requiring any clarification of the bidding documents may notify the Employer in writing or through E-mail at the Employer's address indicated in the invitation to bid. The Employer will respond to any request for clarification which he received earlier than 15 days prior to the deadline for submission of bids. Employer's response will be published on website including a description of the enquiry but without identifying its source.

9.2. Pre-bid meeting (Deleted)

10. Amendment of Bidding Documents

- 10.1 Before the deadline for submission of bids, the Employer may modify the bidding documents by issuing addenda.
- 10.2. Any addendum thus issued shall be part of the bidding documents. The Employer will assume no responsibility for the same.
- 10.3. To give prospective bidders reasonable time in which to take an addendum into account in preparing their bids, the Employer may, at his discretion, extend as necessary the deadline for submission of bids, in accordance with Sub-Clause 20.2 below.

C. PREPARATION OF BIDS

11. Language of the Bid

11.1 All documents relating to the bid shall be in the English language.

12. Documents Comprising the Bid

12.1. The bid be submitted by the bidder as Volume V of the bid document (refer Clause 8.1) shall be in two separate parts:

Part I shall be named "Technical Bid" and shall comprise

(i) Registration Certificate

Part II shall be named "Financial Bid" and shall comprise

(i) Form of Bid as specified in Section 6

(ii) Priced Bill of Quantities for items specified in Section 7

12.2. The Bidder shall submit the details / information pertaining to each part i.e. technical as well as financial and must be submitted online only.

12.3. Following documents will be deemed to be part of the bid.

Section	Particulars	Volume No.
	Invitation for Bids (IFB)	
1	Instruction to Bidders	Volume I
3	Conditions of Contract	
4	Contract Data	
5	Specifications	Volume II
9	Drawings	Volume IV

13. Bid Prices

13.1 The Contract shall be for the whole works as described in Sub-Clause 1.1, based on the priced Bill of Quantities submitted by the Bidder.

13.2 The bidder shall fill in rates and prices and line item total (both in figures and words) for all items of the Works described in the Bill of Quantities along with total bid price (Both in figures and words). Items for which no rate or price is entered by the bidder will not be paid for by the Bill of Quantities.

13.3 All duties, taxes, and other levies except GST payable by the contractor under the contract, or for any other cause shall be included in the rates, prices and total Bid Price submitted by the Bidder. (GST will be paid extra)

13.4 Deleted

13.5 The rates and prices quoted by the bidder are subject to adjustment during the performance of the Contract in accordance with the provisions of Clause 47 of the Condition of Contract (**Irrespective of the time limit and Bid Amount**)

14. Currencies of Bid and Payment

- 14.1 The unit rates and the prices quoted by the bidder shall be entirely in Indian Rupees. All payments shall be made in Indian Rupees.

15. Bid Validity

- 15.1 Bids shall remain valid for a period of not less than 120 days after the deadline date for bid submission specified in Clause 20.
- 15.2 In exceptional circumstances, prior to expiry of the original time limit, the Employer may request that the bidders may extend the period of validity for a specified period. A bidder may refuse the request without forfeiting his bid security. A bidder agreeing to the request will not be required or permitted to modify his bid, but will be required to extend the validity of his security for a period of the extension, and in compliance with Clause 16 in all respects.

16. Bid Security

- 16.1. The Bidder shall furnish, as part of his Bid, a Bid security in the amount as shown in column 4 of the table of IFB for this particular work. This Bid security shall be in favor of Registrar Gujarat National Law University Gandhinagar in Appendix and may be in one of the following forms;
- a. Bank Guarantee from any scheduled Indian bank, in the format given in Volume III. **(Bank Guarantee is applicable only for Bid Estimated Amount of 01 Crore and above) and Bank Guarantee of Schedule and Private Banks shall be considered as per GoG Finance Department's Circular No. FD/MSM/e-file/4/2023/0057/D.M.O. Date 21/04/2023 or as per their latest amendment.**
- b. Fixed Deposit Receipt issued by any Scheduled Indian Bank or a foreign Bank approved by the Reserve Bank of India.
- OR**
- A Valid Bid Security / EMD Exemption Certificate issued by (1) Road & Building Department or (2) Narmada Water Resources, Water Supply and Kalpsar Department of Govt of Gujarat. **Exemption Certificate is applicable only when Registration Certificate of Appropriate Class and Category of Approved Contractors is required as eligible criteria of bidder.**
- 16.2. Bank guarantees (and other instruments having fixed validity) issued as surety for the bid shall be valid for 45 days beyond the validity of the bid i.e. total validity of 120+45 = 165 Days
- 16.3. Any bid not accompanied by an acceptable Bid Security and not secured as indicated in Sub-Clauses 16.1 and 16.2 above shall be rejected by the Employer as non-responsive.
- 16.4. The Bid Security of unsuccessful bidders will be returned within 28 days of the end of the bid validity period specified in Sub-Clause 15.1
- 16.5. The Bid Security of the successful bidder will be discharged when the bidder has signed the Agreement and furnished the required Performance Security.
- 16.6. The bid Security may be forfeited

- (a) If the Bidder withdraws the bid after Bid opening during the period of Bid validity.
- (b) If the Bidder does not accept the correction of the Bid Price, if any or
- (c) In the case of a successful Bidders, if the Bidder fails the specified time limit to
 - (i) Sign the Agreement; or
 - (ii) Furnish the requirement Performance Security.
- (d) #If found necessary, the bidder will be intimated for negotiation, He will be intimated maximum three times within the validity period for negotiation, If contractor does not respond in time, his Bid Security (EMD) will be forfeited and his tender will be rejected. Punitive action will be taken on such contractors. (As per GoG R&B Dept's Gr. No. S/22/2017/639/D, Dt.08/06/2018)

17. Alternative Proposals by Bidders.

- 17.1. Bidders shall submit offers that fully comply with the requirements of the bidding documents, including the conditions of contract (including mobilization advance or time for completion), basic technical design as indicated in the drawing and specifications. Conditional offers or alternative offers will not be considered further in the process of tender evaluation.

18. Format and Signing of Bid

- 18.1. The Bidder shall prepare documents comprising the bid as described in Clause 12 of these Instructions to bidder as the "Technical Bid "and "Financial Bid" in separate parts to be uploaded.

D. SUBMISSION OF BIDS

19. Deleted

20. Deadline for Submission of the Bids

- 20.1. Complete Bids must be received online by the Employer at the tender website specified above not later than the date indicated in appendix.
- 20.2. The Employer may extend the deadline for submission of bids by issuing an amendment in accordance with Clause 10, in which case all right and obligation of the Employer and the bidders previously subject to the original deadline will then be subject to the new deadline.

21. Deleted

22. Modification and Withdrawal of Bids

- 22.1. Bidders may modify or withdraw their bids online before the deadline prescribed in Clause 20 or pursuant to Clause 23.
- 22.2 Deleted
- 22.3. No bid shall be modified or withdrawn after the deadline for submission of Bid.
- 22.4. Withdrawal or modification of a bid between the deadline for submission of bids and the expiration of the original period of bid validity specified in Clause 15.1 above or as extended pursuant to Clause 15.2 may result in the forfeiture of the Bid security pursuant to Clause 16.

E. BID OPENING AND EVALUATION

23. Bid Opening

- 23.1 The Employer will open all the Bids received including modifications made pursuant to Clause 22, in the presence of the Bidders or their representatives who choose to attend at time, date and the place specified in Appendix in the manner specified in Clauses 20 and 23.3, In the event of the specified date of Bid opening being declared a holiday for the Employer, the Bids will be opened at the appointed time and location on the next working day.
- 23.2. Deleted.
- 23.3. The “Technical Bid” shall be opened. The amount, form and validity of the bid security furnished with each bid will be announced. If the bid security furnished does not conform to the amount and validity period as specified in the invitation for bid (ref. Column 4 and paragraph 3), and has not been furnished in the form specified in Clause 16, the technical bid will not be opened.
- 23.4. (i) Subject to confirmation of the bid security by the issuing Bank, the bids accompanied with valid bid security will be taken up for evaluation with respect to the Qualification information and other information furnished in part I of the bid pursuant to Clause 12.1.
- (ii) If required, the bidder will be asked in writing to clarify his Qualification Documents with respect to any required clarification.
- (iii) The bidders will respond in not more than 7 days of issue of the clarification letter.
- (iv) Immediately (usually within 3 or 4 days), on receipt of these clarification the Evaluation Committee will finalize the list of responsive bidders whose financial bids are eligible for consideration.
- 23.5. Deleted
- 23.6 At the time of opening of “Financial Bid”, the names of the bidders were found responsive in accordance with Clause 23.4(iv) will be announced. The bids of only these bidders will be opened. The responsive Bidders’ names, the Bid prices, the total amount of each bid, any discount and such other details as the Employer may consider appropriate, will be announced by the Employer at the opening.
- 23.7 the time of opening of “Financial Bid”, the names of the bidders were found responsive in accordance with Clause 23.4(iv) will be announced. The bids of only these bidders will be opened. The responsive Bidders’ names, the Bid prices, the total amount of each bid, any discount, and such other details as the Employer may consider appropriate, will be announced by the Employer at the opening.
- 23.8 In case bids are invited for more than one package, the order for opening of the “Financial Bid” shall be in order of Estimated amount of Bids from highest to lowest.
- 23.9 The Employer shall prepare minutes of the Bid opening, including the information disclosed to those present in accordance with Sub-Clause 23.6.

24 Process to be Confidential

- 24.1 Information relating to the examination, clarification, evaluation, and comparison of Bids and recommendations for the award of a contract shall not be disclosed to Bidders or any other persons not officially concerned with such process until the award to the

successful Bidder has been announced. Any effort by Bidder to influence the Employer's processing of Bids or award decisions may result in the rejection of his Bid.

25. Clarification of Financial Bids

- 25.1. To assist in the examination, evaluation, and comparison of Bids, the Employer may, at his discretion, ask any Bidder for clarification of his Bid, including breakdowns of unit rates. The request for clarification and the response shall be in writing or by e-mail, but no change in the price or substances of the Bid shall be sought, offered, or permitted except as required to confirm the correction of arithmetic errors discovered by the Employer in the evaluation of the Bids.
- 25.2 Subject to sub-clause 25.1, no Bidder shall contact the Employer on any matter relating to his Bid opening to the contract is awarded. If the Bidder wishes to bring additional information to the notice of the Employer, it should do so in writing.
- 25.3. Any effort by the Bidder to influence the Employer in the Employer's bid evaluation, bid comparison or contract award decision may result in the rejection of the Bidders' bid.

26. Examinations of Bids and Determination of Responsiveness

- 26.1 During the detail evaluation of "Technical Bid", the Employer will determine whether each Bid (a) meets the eligibility criteria defined in Clause 3 and 4; (b) has been properly signed; (c) is accompanied by the required securities and; (d) is substantially responsive to the requirements of the Bidding document. During the detailed evaluation of the "Financial Bid", the responsiveness of the bids will be further determined with respect to the remaining bid conditions, i.e., priced bill of quantities, technical specifications, and drawings.
- 26.2 A substantially responsive "Financial Bid" is one which confirms all the terms, conditions and specifications of bidding documents, without material deviation or reservation. A material deviation or reservation is one (a) which affects in any substantial way the scope, quality, or performance of the Works; (b) which limits in any substantial way, inconsistent with the Bidding documents, the Employer's rights or the Bidder's obligations under the Contract; or (c) whose rectification would affect unfairly the competitive position of other Bidders presenting substantially responsive Bids.
- 26.3 If a "Financial Bid" is not substantially responsive, it will be rejected by the Employer, and may not subsequently be made responsive by correction or withdrawal of the non-conforming deviation or reservation.

27. Deleted.

28. Deleted

29. Evaluation and Comparison of Financial Bids

- 29.1. The Employer will evaluate and compare only the Bids determined to be substantially responsive in accordance with Sub-Clause 26.2.
- 29.2. Deleted.
- 29.3. The Employer reserves the right to accept or reject any variation or deviation.

Variation and deviations and other factors, which are in excess of the requirements of the Bidding documents or otherwise result in unsolicited benefits for the Employer, shall not be taken in to account in Bid evaluation.

- 29.4. The estimated effect of the price adjustment conditions under Clause 47 of the Conditions of Contract, during the period of implementation of the Contract, will not be taken in to account in Bid evaluation.
- 29.5. If the Bid of the successful Bidder is seriously unbalanced in relation to the Engineer's estimate of the cost of work to be performed under the contract the Employer may require the Bidder to produce detailed consistency of those prices with the construction methods and schedule proposed. After evaluation of the price analyses, the Employer may require that the amount of the performance security set forth in Clause 34 be increased at the expense of the successful /bidder to a level sufficient to protect the Employer against financial loss in the event of default of the successful Bidder under the Contract.
- 29.6. A bid which contains several items in the bill of Quantities which are unrealistically priced low and which cannot be substantiated satisfactorily by the bidder may be rejected as non-responsive.

30. Deleted

F. AWARD OF CONTRACT

31. Award Criteria

- 31.1. Subject to Clause 32, the Employer will award the contract to the Bidder whose Bid has been determined.
- (i) to be substantially responsive to the Bidding documents and who has offered the lowest evaluated Bid Price; and
 - (ii) to be within the available bid capacity adjusted to account for his bid price which is the lowest evaluation in any of the packages opened earlier than the one consideration.
- In no case, the contract shall be awarded to any bidder whose available bid capacity is less than the evaluated bid price, even if the said bid is the lowest evaluated bid. The contract will in such cases be awarded to the next lowest bidder at his evaluation bid price.

32. Employer's Right to Accept any Bid and to Reject any or all Bids

- 32.1. Notwithstanding Clause 31, the Employer reserves the right to accept or reject any Bid, and to cancel the Bidding process and reject all Bids, at any time prior to the award of contract, without thereby incurring any liability to the affected bidder or Bidder or any obligation to inform the affected Bidder or Bidders of the grounds for the Employer's action.

33. Notification of Award and Signing of Agreement

- 33.1. The Bidder whose Bid has been accepted will be notified of the award by the Employer prior to expiration of the Bid validity period by cable, telex or facsimile confirmed by registered letter. This letter (hereinafter and in the condition of contract called the "Letter of Acceptance") will state the sum that the Employer will pay the Contractor in consideration of the execution, completion, and maintenance of the Works by the Contractor as prescribed by the Contract (hereinafter and in the Contract called the "Contract Price").
- 33.2. The notification of award will constitute the formation of the contract, subject only to the furnishing of a performance security in accordance with the provisions of Clause.
- 33.3. The Agreement will incorporate all agreements between the Employer and the successful Bidder. It will be signed by the Employer and to the successful Bidder, within 28 days following the notification of award along with the Letter of Acceptance. Within 21 days of receipt, the successful Bidder will sign the Agreement and deliver it to the Employer.
- 33.4. Upon the furnishing by the successful Bidder of the Performance Security, the Employer will promptly notify the other Bidders that their Bids have been unsuccessful.

34. Performance Security

- 34.1. (A) Within 10 (Ten) days of receipt of Letter of Acceptance, the successful Bidder shall furnish to the Employer an irrevocable and unconditional guarantee from a Bank in the form set forth in Section 8 (the "Performance Security") for an amount equal to 5% (five percent) of its Contract Price. In case of bids mentioned below, the successful Bidder, along with the Performance Security,

shall also furnish to the Authority an irrevocable and unconditional guarantee from a Bank in the same form given at Section 8 towards an Additional Performance Security (The "Additional Performance Security") for an amount calculated as under:

- (a) If the Contract Price offered by the Selected Bidder is lower than 10% but upto 20% of the Estimated Project Cost, then the Additional Performance Security shall be calculated @ 20% of the difference in the (i) Estimated Project Cost (as mentioned in Bid Document) - Minus 10% of the Estimated Project Cost and (ii) Contract Price offered by the selected Bidder.
 - (b) If the Contract Price offered by the Selected Bidder is lower than 20% of the Estimated Project Cost, then the Additional Performance Security shall be calculated @ 30% of the difference in the (i) Estimated Project Cost (as mentioned in Bid Document) - Minus 10% of the Estimated Project Cost and (ii) Contract Price offered by the selected Bidder.
 - (c) This Additional Performance Security shall be treated as part of the Performance Security.
- (B) The Performance Security shall be valid beyond 60(sixty) days of the Defects Liability Period and the Additional Performance Security shall be valid beyond 28 (twenty-eight) days of Project Completion Date.

34.2. If the performance security is provided by the successful Bidder in the form of a Bank Guarantee, it shall be issued either (a) at the Bidder's option, by a Nationalized/Scheduled Indian bank or (b) by a foreign bank located in India and acceptable to the Employer. As per GoG Finance Department's Circular No. FD/MSM/e-file/4/2023/0057/D.M.O. Date 21/04/2023 or as per their latest amendment.

34.3. Failure of the successful Bidder to comply with the requirement of Sub-Clause 34.1 shall constitute sufficient grounds for cancellation of the award and forfeiture of the Bid Security.

35 Advance Payment and Security

35.1 The Employer will provide an Advance payment on the Contract Price as stipulated in the Conditions of Contract, subject to maximum amount, as stated in the Contract Data.

36. Deleted

37. Corrupt of Fraudulent Practices

37.1 The Employer will reject a proposal if it determines that the Bidder recommended for award has engaged in corrupt or fraudulent practices in completing for the contract in question and will declare the firm ineligible, either indefinitely or for a stated period of time, to be awarded a contract with National Highways Authority of India/ State PWD and any other agencies, if it at any time determines that the firm has engaged in corrupt or fraudulent practices in completing for the contractor, or in execution.

37.2 Furthermore, Bidders shall be aware of the provision stated in Sub- Clause 59.2 of the Conditions of Contract.

APPENDIX TO ITB
Clause Reference With
respect to Section -I

1. The Name of the Employer is Registrar Gujarat National Law University, Attalika Avenue, Knowledge corridor, Koba, Gandhinagar [Cl.1.1]
2. Deleted
3. Deleted [Cl.4.5.3 (a)]
4. Value of Work : Deleted
5. Deleted
6. The cost of electric work: Deleted
7. The cost of water supply / sanitary works :Deleted
8. Liquid assets and / or availability of credit facilities is Rs.37,80,000/- [Cl.4.5.6]
9. **Price level of the financial year 2023-2024** [Cl. 4.5.2]
10. The pre-bid meeting will take place : N.A. [Cl. 9.2.1]
11. The technical Bid will be opened :
12. Address of the Employer: Gujarat National Law University, Attalika Avenue, Knowledge corridor, Koba, Gandhinagar
13. Deleted
14. The bid should be submitted latest by As stated on online NIT [Cl. 20.1 & 20.2]
15. The bid will be opened at Gujarat National Law University, Attalika Avenue, Knowledge corridor, Koba, Gandhinagar As stated on [Cl. 23.1]
16. The Bank Draft in favor Registrar Gujarat National Law University, Gandhinagar
17. Deleted
18. Escalation factors :Deleted [Cl.4.5.2]

#LIST OF KEY PLANT & EQUIPMENT TO BE DEPLOYED ON CONTRACT

WORK [Reference CL. 4.5.5] Deleted

List of Key Personnel to be deployed on Contract Work

(Reference Cl. 4.5.4)

Employment of a qualified site Engineer by the Contractor.

The Contractor shall employ full-time technically qualified staff during the execution of this work as under: -

1. Two graduate Civil Engineers and three diploma Civil Engineers when cost of the work to be executed is more than Rs.50 lakhs.
2. One graduate & two Diploma, Civil Engineers when the cost of the work to be executed is more than Rs.15 lakhs but less than Rs.50 lakhs.
3. Minimum Two Diploma Civil Engineer when the cost of work is less than Rs.15 lakhs but more than Rs.5 lakhs.
4. Minimum One Diploma Civil Engineers for the work when the cost of work to be executed is less than Rs. 5 lakhs. The Engineer so employed for the Government work must have sufficient experience to handle the work independently. Such an Engineer shall have to stay at the site of work and he shall not be entrusted with other duty except this work.

In case the contractor or partner of the contractor firm is a Civil Graduate Engineer, Employment of a separate Engineer will not be necessary provided that the Engineer partner himself attends the execution of the work on the site.

Within 15 days of issue of work-order the Contractor will have to furnish to the Engineer-in-charge of the work the Name, Qualifications, copy of marksheet, Color Photograph and the appointment order issued such engineers engaged for this contract work. If 15 days after issue of work order such designated Site Engineers do not resume or do not remain present on site of work, the recovery at the rate of Rs.15,000-00 per month per Engineer will be made from the bills/deposit/dues of the contractor. Such recovery shall be non-refundable.

SECTION - 2
QUALIFICATION INFORMATION

QUALIFICATION INFORMATION

The information to be filled in by the Bidder in the following pages will be used for the purpose of post qualification as provided for in Clause 4 of the Instruction to Bidders. This information will not be incorporated in the Contract.

1. For Individual Bidders

1.1 Constitution or legal status of Bidder (Attach Copy)

Place of registration _____

Principal place of business _____

Power of attorney of signatory of Bid

(Attach)

1.2 Total value of Civil engineering constructions Deleted
Work performed in the last five years

1.3.1 Work performed as prime contractor, Deleted. Deleted

1.3.Deleted

1.4 Deleted.

1.5—Deleted

1.6 Deleted

1.7 Deleted

1.8 Deleted

1.9 Deleted

1.10 Name, address, and telephone, telex, and fax numbers of the Bidders bankers who may provide references if contacted by the Employer.

1.11 Information on Litigation history in which the Bidder is involved.

Other Parties)	Employer	Cause of Dispute	Amount Involved	Remarks showing Present Status

1.12. Statement of compliance under the requirements of Sub Clause 3.2 of the instruction to Bidders. (Name of Consultant engaged for project preparations is *)

1.13 Proposed work method and schedule. The Bidder should attach descriptions, drawings and charts as necessary to comply with the requirements of the Bidding documents. (Refer ITB Clause 4.1)

1.14 Programme

~~2.~~ Deleted

3. Additional Requirements

3.1 Bidders should provide any additional information required to fulfill the requirements of Clause 4 of the Instructions to the Bidders, if applicable.

(i) Affidavit

(ii) Undertaking

* Fill the name of Consultant

AFFIDAVIT

1. I, the undersigned, do hereby certify that all the statements made in the required attachments are true and correct.

2. The undersigned also hereby certifies that neither our firm M/s. _____
_____ have not abandoned any work of Government of Gujarat/Government of India/any Board or Corporation under Government of Gujarat/Government of India nor any contract awarded to us for such works have been rescinded, during last five years prior to the date of this bid.

3. The undersigned hereby authorize(s) and request (s) any bank, person, firm or corporation to furnish pertinent information deemed necessary and requested by the Department to verify this statement or regarding any (our) competence and general reputation.

4. The Undersigned understands and agrees that further qualifying information may be requested, and agrees to furnish any such information at the request of the Department/ Project implementing agency.

(Signed by an Authorized Officer of the Firm)

Title of Officer

Name of Firm

Date

UNDERTAKING

I, the undersigned do hereby undertake that our firm M/s.....would invest a minimum cash up to 25% of the value of the work during implementation of the contract.

(Signed by an Authorized officer of the firm)

Title of officer

Name of firm

DATE

SECTION - 3
CONDITIONS OF CONTRACT

CONDITIONS OF CONTRACT

A. GENERAL.

1. Definitions

1.1 Terms which are defined in the Contract Data are not also defined in the Conditions of Contract but keep their defined meaning.

Bill of Quantities means the priced and completed Bill of Quantities forming part of the Bid

Compensation Events are those defined in Clause 44 hereunder

The **Completion Date** is the date of completion of the Works as certified by the Engineer in accordance with Sub Clause 55.1

The Contract is the contract between the Employer and Contractor to execute, complete and maintain the Works **till the completion of Defects Liability Period**. It consists of the documents listed in Clause 2.3 below.

The **Contract data** defines the documents and other information which comprise the Contract.

The **Contractor** is a person or corporate body whose Bid to carry out the Work has been accepted by the Employer.

The **Contractor's Bid** is the completed Bidding document submitted by the Contractor to the Employer and includes Technical and Financial Bids.

The **Contract Price** is the price stated in the Letter of Acceptance and thereafter as adjusted in accordance with the provisions of the Contract.

Days are calendar days: **months** are calendar months.

The **Defects Liability Period** is the period named in the Contract Data and calculated from the Completion Date.

The **Employer** is the party who will employ the Contractor to carry out the Works.

The Engineer is the person named in the Contract Data (or any other competent person appointed and notified to the contractor to act in replacement of the Engineer) who is responsible for supervising the Contractor, administering the Contract, certifying payments due to the Contractor, issuing and valuing Variations to the Contract, awarding extensions of time, and valuing the Compensations Events.

While dealing with the financial approval and items like extra items, quantity variations and other such proposals involving the finance where the terms should mean the competent authority under the organization having competency to deal with and approve such cases.

Equipment is Contractor's machinery and vehicles brought temporarily to the site to construct the Works.

The **Initial Contract Price** is the Contract Price listed in the Employer's Letter of Acceptance.

The **Intended Completion Date** is the date on which it is intended that the Contractor shall complete the Works. The Intended Completion Date is specified in the Contract Data. The Intended Completion Date may be revised only by the Engineer by issuing an extension of time.

Materials are all supplies, including consumables, used by the contractor for incorporation in the works.

Plant is any integral part of the work which is to have mechanical, electrical, electronic or chemical or biological functions.

The **Site** is the area defined as such in the Contract Data.

Site Investigation Reports are those which were included in the Bidding documents and are factual interpretive reports about the surface and subsurface conditions at the site.

Specifications means the Specifications of the works included in the Contract and any modification or addition made or approved by the Engineer.

The **Start Date** is given in the Contract Data. It is the date when the Contractor shall commence execution of the works. It does not necessarily coincide with any of the Site Possession Dates.

A **Subcontractor** is a person or corporate body who has a Contract with the Contractor to carry out a part of the work in the Contract which includes work on the Site.

Temporary Works are works designed, constructed, installed, and removed by the Contractor which are needed for construction or installation of the Works.

A **Variation** is an instruction given by the Engineer, which varies the Works.

The **Works** are what the Contract requires the Contractor to construct, install, and turn over to the Employer, as defined in the Contract Data.

2. Interpretation

2.1 In interpreting these Conditions of Contract, singular also means plural, male also means female or neuter and the other way around. Headings have no significance. Words have their normal meaning under the language of the Contract unless specifically defined. The Engineer will provide instructions clarifying queries about Conditions of Contract.

2.2 If sectional completion is specified in the Contract Data, references in the Conditions of Contract to the Works, the Completion date, and Intended Completion Date apply to any Section of the Works (other than references to the Completion Date and Intended Completion date for the whole works)

2.3 The documents forming the Contract shall be interpreted in the following order of priority

- (1) Agreement
- (2) Letter of Acceptance, notice to proceed with works
- (3) Contractor's Bid

- (4) Contract Data
- (5) Conditions of Contract including Conditions of Contract
- (6) Specifications
- (7) Drawings
- (8) Bills of quantities and
- (9) Any other document listed in the Contract Data as forming part of the Contract.

3. Language and Law

- 3.1 The language of the Contract and the law governing the Contract are stated in the Contract Data.

4. Engineers Decisions

- 4.1 Except where otherwise specifically stated, the Engineer will decide contractual matters between the Employer and the Contractor in the role representing the Employer. The Engineer shall obtain approval of competent authority if needed as per delegation of powers of GNLU.

5. Delegation

- 5.1 The Engineer may delegate any of his duties and responsibilities to other people after notifying the Contractor and may cancel any delegation after notifying the Contractor.

6. Communications

- 6.1 Communications between parties which are referred to in the conditions are effective only when in writing. A notice shall be effective only when it is delivered (in terms of Indian Contract Act).

7. Sub-Contracting : Deleted

- 7.1 Deleted.

- 7.2 Deleted

8. Other Contractors

- 8.1 The Contractor shall cooperate and share the Site with other contractors, public authorities, utilities and the Employer between the dates given in the Schedule of other Contractor. The Contractors shall as refer to in the Contract Data, also provide facilities and services for them as described in the Schedule. The employer may modify the schedule of other contractors and shall notify the contractor of any such modifications.

9. Personnel

- 9.1 The Contractor shall employ the key personnel named in the Schedule of Key Personnel as referred to in the Contract Data to carry out the functions stated in the Schedule or other personnel approved by the Engineer. The Engineer will approve any proposed replacement of key personnel only if their qualifications, abilities, and relevant experience are substantially equal to or better than those of the personnel listed in the Schedule.
- 9.2 If the engineer asks the Contractor to remove a person who is a member of the Contractor Staff or his work force stating the reasons the Contractor shall

ensure that the person leaves the Site within seven days and has no further connection with the work in the Contract.

10. Employer's and Contractors Risks

10.1 The Employer carries the risk which these Contract states are Employer's risks, and the Contractor carries the risks which these Contracts states are Contractors risk.

11. Employer's Risks

11.1 The employer is responsible for the excepted risks which are (a) in so far as they directly affect the execution of the Works, the risks of war, hostilities, invasion, act of foreign enemies, rebellion, revolution, insurrection or military or usurped power, civil war, riot commotion or disorder (unless restricted to the Contractor's employees), and contamination from any nuclear fuel or nuclear waste or radioactive toxic explosive.

12. Contractor's Risks

12.1 All risks of loss of or damages to physical property and of personal injury and death which arise during and in consequence of the performance of the Contract other than the excepted risks are the responsibility of the Contractor.

13. Insurance

13.1 The Contractor shall provide, in the joint names of the Employer and the Contractor, insurance cover from the Start date to the end of the Defects Liability Period, in the amounts and deductibles stated in the Contract data for the following events which are due to the Contractor's risks:

(a) Loss of or damage to the works, Plant and materials,

(b) Loss of or damage to Equipment

(c) Loss of or damages of property (except the Works, Plant, Materials and Equipment) in connection with the Contract; and

(d) Personal injury or death.

13.2 Policies and certificates for insurance shall be delivered by the Contractor to the Engineer for the Engineer's approval before the Start Date. All such insurance shall provide for compensation to be payable in the types and proportions of currencies required to rectify the loss or damage incurred.

13.3 If the Contractor does not provide any of the policies and certificates required, the Employer may affect the insurance which the Contractor should have provided and recover the premiums the Employer has paid from payments otherwise due to the Contractor or, if no payment is due, the payment of the premiums shall be a debt due.

13.4 Alterations to the terms of an insurance shall not be made without the approval of the Engineer.

13.5 Both parties shall comply with any conditions of the insurance policies.

14. Site Investigation Report

- 14.1 The Contractor in preparing the Bid shall rely on any site Investigation reports referred to in the Contract Data, supplemented by any information available to the Bidder.

15. Queries about the Contract data

- 15.1 The engineer will clarify queries on the Contract Data

16. Contractor to Construct the Works

- 16.1 The Contractor shall construct and install the works in accordance with the specification and Drawings.

17. The Works to be completed by the Intended Completion Date

- 17.1 The Contractor may commence execution of the Works on the Start Date and shall carry out the Works in accordance with the programme submitted by the Contractor, as updated with the approval of the Engineer, and complete them by the Intended Completion date

18. Approval by the Engineer

- 18.1 The Contractor shall submit Specifications and Drawings showing the proposed Temporary works to the Engineer, who is to approve them if they comply with the Specifications and drawings.
- 18.2 The Contractor shall be responsible for design of temporary works.
- 18.3 The Engineer's approval shall not alter the contractor responsibility for design of the Temporary works.
- 18.4 The Contractor shall obtain approval of third parties to the design of the Temporary works where required.
- 18.5 All Drawings prepared by the Contractors for the execution of the temporary or permanent work are subject to prior approval by the Engineer before their use.

19. Safety

- 19.1 The Contractor shall be responsible for the safety of all activities on the Site.

20. Discoveries

- 20.1 Anything of historical or other interest or of significant value unexpectedly discovered on the site is the property of the Employer. The contractor is to notify the engineer of such discoveries and carry out the Engineer's instructions for dealing with them.

21. Possession of the Site

- 21.1 The Employer shall give possession of all parts of the site to the Contractor. If possession of a part is not given by the date stated in the Contract Data the Employer is deemed to have delayed the start of the relevant activities and this will be a Compensation Event.
- 21.2 If within 25% of the time limit of the project, 80% of possession of the site is not handed over to the Contractor, then contractor/ Employer may fore-close the contract. Contractor/Employer has to foreclose the work within 30 days

after lapse of 25%-time limit and after 30 days foreclosure option will be closed.

22. Access to the Site

22.1 The Contractor shall allow the Engineer and any person authorized by the Engineer access to the Site, to any place where work in connection with the Contract is being carried out or is intended to be carried out and to any place where materials or plants are being manufactured/ fabricated/ assembled for the works.

23. Instructions

23.1 The Contractor shall carry out all instructions of the Engineer pertaining to works which comply with the applicable laws where the site is located.

23.2 The Contractor shall permit the Employer to inspect the Contractor's accounts and records relating to the performance of the Contractor and to have them audited by auditors appointed by the Employer, if so required by the Employer.

24. Disputes

24.1 If the Contractor is of the view that a decision taken by the Engineer was either outside the authority given to the Engineer by the Contract or that the decision was wrongly taken, the decision shall be referred to **COMPETENT AUTHORITY OF Gujarat National Law University**, within 14 days of the notification of the Engineer's decision. If the issue is not resolved, any party can refer the matter for conciliation within 15 days from the decision given by such competent authority.

24.2 If any of the parties is not satisfied with the decision of the **COMPETENT AUTHORITY, Director, Gujarat National Law University** both the parties have to refer to the Director for the conciliation process. If the dispute is not resolved through the conciliation process, he may refer the dispute to Gujarat Public Works Contract Dispute Arbitration Tribunal. If the Contractor fails to refer a claim / dispute to the Higher Authority within 14 days of the notification of the Engineer's decision, the Contractor shall not be entitled to any additional payment/claim if he doesn't follow the above sequence in stipulated time and he should not stop the work.

25. Procedure for Disputers

25.1 The arbitration shall be conducted in accordance with the arbitration procedure stated in the Special Conditions of Contract.

26. Deleted

B. TIME CONTROL

27. Programme

- 27.1 Within the time stated in the Contract Data the Contractor shall submit to the Engineer for approval a Programme showing the general methods, arrangements orders, and timing for all the activities in the works along with monthly cash flow forecast.
- 27.2 An update of the Programme shall be a programme showing the actual progress achieved on each activity and the effect of the progress achieved on the timing of the remaining work including any changes to the sequence of the activities.
- 27.3 The Contractor shall submit to the Engineer, for approval an updated programme at intervals no longer than the period stated in the Contract data. If the Contractor does not submit an updated programme within this period, the Engineer may withhold the amount stated in the Contract data from the next payment after the date on which the overdue programme has been submitted.
- 27.4 The Engineer's approval of the programme shall not alter the Contractor's obligations. The Contractor may revise the programme and submit it to the Engineer again at any time. A revised programme is to show the effect of Variations and Compensations events.

28. Extension of the Intended Completion Date

- 28.1 The Engineer shall extend the Intended Completion Date if a compensation Event occurs or a Variation is issued which makes it impossible for completion to be achieved by the Intended Completion Date without the Contractor taking steps to accelerate the remaining work and which would cause the Contractor to incur additional cost.
- 28.2 The Engineer shall decide whether and by how much to extend the Intended Completion Date within 35 days of the Contractor asking the Engineer for a decision upon the effect of a compensation event or Variation and submitting full supporting information. If the Contractor has failed to give early warning of a delay or has failed to cooperate in dealing with a delay, the delay by this failure shall not be considered in assessing the new Intended Completion Date.
- 28.3 The Engineer shall within 14 days of receiving full justification from the contractor for extension of Intended Completion Date refer to the Employer his decision. The employer shall in not more than 21 days communicate to the engineer the acceptance or otherwise of the Engineer's decision. If the employer fails to give his acceptance, the Engineer shall not grant the extension and the contractor may refer the matter under Clause 24.1

29. Deleted

30. Delays Ordered by the Engineer

- 30.1 The Engineer may instruct the Contractor to delay the start or progress of any activity within the works.

31. Management Meetings

31.1 Either the Engineer or the Contractor may require the other to attend a management meeting. The business of a management meeting shall be to review the plans for remaining work and to deal with matters raised in accordance with the early warning procedure.

31.2 The Engineer shall record the business of management meetings and is to provide copies of his record to those attending the meeting and to the Employer. The responsibility of the parties for actions to be taken is to be decided by the Engineer either at the management meeting or after the management meeting and stated in writing to all who attended the meeting.

32. Early Warning

32.1 The Contractor is to warn the Engineer at the earliest opportunity of specific likely future events or circumstances that may adversely affect the quality of the work, increase the Contract price or delay the execution of works. The Engineer may require the contractor to provide an estimate of the expected effect of the future event or circumstance on the contract price and completion date. The estimate is to be provided by the Contractor as soon as reasonably possible.

32.2 The Contractor shall cooperate with the Engineer in making and considering proposals for how the effect of such an event or circumstance can be avoided or reduced by anyone involved in the work and in carrying out any resulting instruction of the Engineer.

C. QUALITY CONTROL

33. Identifying Defects/ Defect liability period

33.1 : Defect liability period: The contractor shall be responsible to make good and remedy at his own expense any defect which may develop or may be noticed before the period mentioned hereunder from the certified date of completion. The Engineer in charge shall give the contractor a notice in writing about the defects and the contractor shall make good the same within 15 days of receipt of the notice. In the case of failure on the part of the contractor, the Engineer-in-charge may rectify or remove or re-execute the work at the risk & cost of the contractor. The Engineer-in-charge shall be entitled to appropriate the whole or any part of the amount of security deposit towards the expenses, if any, Incurred by him in rectification, removal or re- execution. The Defects Liability period shall be as under....

- (a) For all works costing up to Rs. 50,000 (amount put to tender), the period shall be 3 Months from the certified date of completion.
- (b) For all works costing more than Rs. 50,000 and up to Rs. 1 crore (amount put tender), the period shall be 12 (Twelve) months from the certified date of completion or one monsoon, whichever is later.
- (c) For major projects costing more than Rs. 1 crore, the period shall be 36 Months from the certified date of completion which should include three monsoons.
- (d) For original building works the defect liability period will be 4 years or elapse of 4 monsoon period following date of possession of building taken over by user agency following the certified date of completion, whichever is later.

For the purpose of deciding the monsoon period, the 30th September shall be treated as the last date.

Modified vide R & B D Circular No. PAC-11-102008-2076-N dated 31/8/2009, PRCH/102013(2976) 2759-N, Dated 27/05/2013 and Circular No.TNC/10/2016/Clause 17A (Correction/(1)C Dated 12/05/2016]

33.2 Deleted

33.3 The Engineer shall check the Contractor's work and notify the Contractor of any defects that are found. Such checking shall not affect the Contractor's responsibilities the Engineer may instruct the Contractor to search for a Defect and to uncover and test any work that the Engineer considers may have a Defect.

33.4 Free maintenance guarantee period for works of construction of Canals/ (including UGPL), Canal Structures, Canal Roads, Hydro Electrical & Mechanical works, Solar, Building Works and Maintenance and Operations.

(a) For the work of Canals (including UGPL), Canal Structures, Canal Roads, Hydro Electrical & Mechanical works, Solar, Building Works and Maintenance and Operations free maintenance guarantee period one year from the date of completion.

(b) During this period the contractor shall visit the site every three months along with the concerned Section Officer / Deputy Executive Engineer and will examine the work already carried out in this contract and attend all defects such as filling rain cuts in banks, jungle cutting, side gutter and all other defects in all structures and its components etc. and will prepare reach wise inspection report duly signed by all concerned and any defect observed shall be done within 15 days by the contractor at his risk and cost as per the direction of Engineer in charge. The contractor needs to do videography of these visits and require to submit at the time of release of

Performance Bond/Performance Security related to Free Maintenance Guarantee The amount equivalent to 5% of each running bill shall be withheld and will be released after the free maintenance guarantee period (i.e. 01 years) is over.

However, this amount shall be released against fixed deposit or bank guarantee pledged in the name of Registrar GNLU Gandhinagar after completion certificate of work is issued

- (1) The materials used for the works during construction shall be as per Indian standards/Technical Specifications of the respective item and all the test as per respective Indian Standards/ Technical Specifications of the respective item shall be conducted and ensured that the test results shall be meet the criteria specified in the relevant clause/specifications for the material in question.
- (2) 2% of the amount shall be withheld till the miscellaneous items like WBM road, testing of canals, side gutters, km stones, canal data board, marble data plates, gauge plates, gate work etc. and in case of UGPL works, trial run, other ancillary work viz. strainer, ladder, pump, well-cover, performance test / trial run of Hydro Mechanical and Electrical works etc, are completed in all respect by the contractor. After completion of the miscellaneous items, the above said 2% withheld amount shall be released.
- (3) Videography for the works under Maintenance Guarantee is to be done as per Govt. letter No.: SSR/10/2015-16/26/C, Dtd. 26/11/15 for the work costing more than estimated cost of Rs. 5.00 Crore.
- (4) Setting up of adequate laboratory & deployment of quality engineers The contractor shall have to set up the laboratory with adequate equipment. Till the setting up of adequate laboratory is completed & reported of this to the engineer (subject to due verification by engineer's representative) by contractor in writing, Rs.2,00,000/- shall be withheld. The qualified quality Engineer shall be deployed exclusively for this contract by the contractors. If quality Engineer is not deployed by contractor within one month after the date of work order, the amount equivalent to Rs.20,000 per month shall be recovered till the actual deployment of quality engineer. The amount so recovered towards the deployment of quality engineers shall not be refunded.
- (5) For finalizing the work, the work carried-out shall be randomly checked by core test for the canal lining works and density tests for embankment works shall have been performed randomly before final bill is paid.
- (6) Maintenance during Construction Period During the Construction Period, the Contractor shall maintain; at his own risk and cost; works for safety are at no time materially inferior as compared to their condition 10 (ten) days prior to the date of the Agreement, and shall undertake the necessary repair and maintenance works for this purpose, provided that the Contractor may. at his cost is necessary for the efficient progress of works and conforms to Good Industry Practice: provided further that such interruption and diversion shall be undertaken by the Contractor only with the prior written approval of the Executive Engineer which approval shall not be unreasonably withheld. For the avoidance of doubt, it is agreed that the Contractor shall at all times be responsible for ensuring safe operation of the work.

34. Tests

- 34.1 If the engineer instructs the Contractor to carry out a test not specified in the Specification to check whether any work has a Defect and the test shows that it does, the Contractor shall pay for the test and any samples. If there is no defect the test shall be a Compensation Event.

34.2 For Confirmatory tests of the testing done by the agencies 1% of the amount of work done should be deducted from R.A. bill of the contractor for testing the quality of material workmanship, irrespective of actual charges.

34.3 Agency has to establish testing laboratory on site for the various test to be carried out in the work for this purpose agency shall construct a pukka laboratory building with all facility on site at location specified by the engineer in charge.

35. Correction of defects

35.1 The engineer shall give notice to the Contractor of any defects before the end of the defects Liability Period, which begins at Completion and is defined in the contract data. The Defects Liability Period shall be extended for as long as Defects remain to be corrected.

35.2 Every time notice of a Defect is given, the Contractor shall correct the notified defect within the length of time specified by the Engineer's notice.

36. Uncorrected Defects

36.1 If the Contractor has not corrected a defect within the time specified in the Engineer's notice, the Engineer will assess the cost of having the Defect corrected, and the Contractor will pay this amount.

D. COST CONTROL

37. Bill of Quantities

- 37.1 The bill of Quantities shall contain items for the constructions, installation, testing and commissioning work to be done by the Contractor.
- 37.2 The bill of Quantities is used to calculate the Contract price. The Contractor is paid for the quantity of the work done at the rate in the Bill of Quantities for each item.

38. Change in the Quantities

- 38.1 The Engineer shall have power to make any alterations in or addition to the original specifications , drawings, designs and instructions that may appear to him to be necessary or advisable during the progress of the work and the contractor shall be bound to carry out the work in accordance with any instruction in this connection which may be given to him in writing signed by the Engineer and such alteration shall not invalidate the contract and any additional work which the contractor may be directed to do in the manner above specified as part of the work shall be carried out by the contractor on the same conditions in all respects on which he agreed to do the main work and at the same rate as are specified in the tender for the main work.

Except that when the quantity of any item exceeds the quantity as in the tender by more than 130%, the contractor will be paid for the quantity in excess of 130%, at the rate entered in the SOR of the year during which the excess in quantity is first executed.

39. Variations

- 39.1 All Variations shall be included in updated programmes produced by the Contractor.

40. Payments for Variations

- 40.1 If the additional or altered work includes any class of work for which no rate is specified in this contract, then such class of work shall be carried out as under.
- (i) At the rate derived from the item within the contract which is comparable to the one involving additional or altered class of work; where there are more than one comparable items, the item of the contract which is nearest in comparison with regard to class or classes of the work involved shall be selected and the decision of the Superintending Engineer as to the nearest comparable item shall be final and binding on the contractor.
 - (ii) If the rate cannot be derived in accordance with (i) above, such class of works shall be carried out at the rate entered in the Schedule of Rates of the division

for the year in which the tender was received, increased or decreased by the percentage by which the tender amount is more or less as compared to the amount arrived at the rates in the "Schedule of Rates" of the Division in the year in which the tender was received. If the Schedule of rates of the Division does not contain all the items, the percentage increase or decrease of the tender shall be calculated considering such items which were included in the "Scheduled Rates" of the division for the year and for materials consumed on such item the rate to be charged would be the basic rate taken into account for fixing the rate in S.O.R. referred to above.

- (iii) If it is not possible to arrive at the rate from (i) and (ii) above, such class of work shall be carried out at the rate decided by the competent authorities on the basis of detailed rate analysis after hearing the contractor before a Committee of two Superintending Engineers stationed at the same place or the nearest place.

40.2 If the additional or altered work, for which no rate is entered in the "Schedule of Rates" of the Division is ordered to be carried out before the rate is agreed upon, then the contractor shall within seven days of the date of receipt by him of the order to carry out the work, inform the Engineer-in-charge of the rate, which it is his intention to charge for such class of work and if the Engineer in charge does not agree to this rates, he shall by notice in writing be at liberty to cancel his order to carry out such class of work and arrange to carry it out in such manner as he may consider it advisable, provided always that if the contractor shall commence work or incur any expenditure in regard thereof before the rates shall have been determined as lastly herein before mentioned, then in such cases he shall only be entitled to be paid in respect of the work carried out or expenditure incurred by him prior to the date of the determination of the rate as aforesaid according to such rate or rates as shall be fixed by the Engineer-in-charge after obtaining approval of the competent authority if needed as per delegation of powers of GNLU. In the event of the dispute, the decision of the competent authority of GNLU shall be final.

Where, however, the work is to be executed according to the designs, drawings and specifications recommended by the contractor and accepted by the competent authority, the alternation above referred to shall be within the scope of such designs, drawings and specifications appended to the tenders.

The time limit for the completion of the work shall be extended in the proportion that the increase in the cost occasioned by alterations bears to the cost of the original work and the certificate of the Engineer-in-charge as to such proportion shall be final and conclusive.

41. Cash Flow Forecasts

- 41.1 When the programme is updated, the contractor is to provide the engineer with an updated cash flow forecast.

42. Payment certificates.

- 42.1 The Contractor shall submit to the Engineer monthly statements of the estimated value of the work completed less the cumulative amount certified previously.
- 42.2 The Engineer shall check the Contractor's monthly statement within 14 days and certify the amount to be paid to the Contractor after taking in to account any credit or debit for the month in question in respect of materials for the works in the relevant amounts and under conditions set forth in sub-clause 32.3 of the Contract Data (secured Advance).
- 42.3 The value of work executed shall be determined by the Engineer.
- 42.4 The value of work executed shall comprise the value of the quantities of the items in the Bill of Quantities completed.
- 42.5 The value of work executed shall include the valuation of variations and compensation events.
- 42.6 The Engineer may exclude any item certified in a previous certificate or reduce the proportion of any item previously certified in any certificate in the light of later information

43. Payments

- 43.1 Payments shall be adjusted for deductions for advance payments, retention, other recoveries in terms of the contract and taxes at source, as applicable under the law. The Employer shall pay the Contractor the amounts certified by the Engineer within 28 days of the date of each certificate.
- 43.2 Payment of GST (prevailing rates) on the amount payable under the contract to the Contractor will be made by the Employer. Hence, it is the responsibility of the contractor to pay the GST to the concerned Authority.
- 43.3 Items of the works for which no rate or price has been entered in will not be paid by the Employer and shall be deemed covered by other rates and prices in the Contract.

44. Compensation events

- 44.1 The following are compensation Events unless they are caused by the Contractor:
- (a) The Employer does not give access to a part of the Site by the site Possession date stated in Contract data to the Contractor
- 44.2 In case of compensation event occurs and it prevents the work being completed beyond the Intended Completion Date then Authority will approve EOT with eligible contractual price escalation.

45. Tax

- 45.1 The rates quoted by the Contractor must be inclusive of all taxes prevailing on due date of bid submission except GST. However, any subsequent changes in the tax structure by Government after due date of bid submission will be compensated (+/-) on availability or submission of actual documentation. Contractor will have to intimate Engineer regarding changes occurred in the tax structure after bid submission. If the contractor fails to provide such

information and if any financial obligation may arise due to change in tax structure, same will be recovered from the contractor.

45.2 GST will be paid separately on the bills. Hence, it is the responsibility of the contractor to pay the GST to the concerned Authority.

46. Currencies.

46.1 All payment shall be made in Indian Rupees.

47. Price Adjustment (Deleted)

48. Retention

48.1 The Employer shall retain from each payment due to Contractor the proportion stated in the Contract Data until Completion of the whole of the Works.

48.2 On Completion of the whole of the Works half the total amount retained is repaid to the Contractor and half when the Defects Liability Period has passed and the Engineer has certified that all Defects notified by the Engineer to the Contractor before the end of this period have been corrected.

48.3 On completion of the whole works, the contractor may substitute retention money with an “on demand” Bank guarantee.

In case, Contractor requests for refund of the Retention Money deducted by the Employer under the provision of this clause, Employer shall consider the said request of the Contractor provided that the refund hereunder shall be made in tranches of not less than 1% (One Percent) of the Contract Price and Contractor furnishes an irrevocable and unconditional Bank guarantee for an equal amount substantially in the format of Bank Guarantee for Performance Guarantee enclosed with SBD and valid up to 60 day beyond the scheduled / extended Defects Liability Period. On completion of the whole works, the contractor has however an option to submit a fresh irrevocable and unconditional Bank Guarantee for an amount equal to 5% of the total value of work executed substantially in the format of Bank Guarantee for Performance Guarantee enclosed with SBD and valid up to 60 days beyond the Defect Liability Period and yet refund the Retention Money Bank Guarantee submitted for refund of Retention Money.

49. Liquidated Damages

49.1 The Contractor shall pay liquidated damages to the Employer at the rate per day stated in the Contract Data for each day that the Completion Date is later than the Intended Completion Date (for the whole works or the milestone as stated in the contract data). The total amount of liquidated damages shall not exceed the amount defined in the Contract Data. The Employer may deduct liquidated damages from payment due to the Contractor. Payment of liquidated damages does not affect the Contractor’s liabilities.

49.2 If the Intended Completion Date is extended after liquidated damages have been paid, the Engineer shall correct any overpayment of liquidated damages

by the Contractor by adjusting the next payment certificate. The Contractor shall not be entitled for any interest on the over payment calculated from the date of payment to the date of repayment.

- 49.3 If the contractor fails to comply with the time for completion as stipulated in the tender, then the contractor shall pay to the employer the relevant sum stated in the Contract Data as Liquidated damages for such default and not as penalty for everyday or part of day which shall elapse between relevant time for completion and the date stated in the taking over certificate of the whole of the works on the relevant section, subject to the limit stated in the contract data.

The employer may, without prejudice to any other method of recovery deduct the amount of such damages from any monies due or to become due to the contractor. The payment or deduction of such damages shall not relieve the contractor from his obligation to complete the works on from any other of his obligations and liabilities under the contract.

- 49.4 If, before the Time for Completion of the whole of the Works or, if applicable any Section, a Taking Over Certificate has been issued for any part of the Works or of a Section, the liquidated damages for delay in completion of the remainder of the Works or of that Section shall, for any period of delay after the date stated in such Taking-Over-Certificate, and in the absence of alternative provisions in the Contract, be reduced in the proportion which the value of the part so certified bears to the value of the whole of the Works or Section, as applicable. The provisions of this Sub-clause shall only apply to the rate of liquidated damages and shall not affect the limit thereof.

50 Bonus: Deleted

51. Advance Payment.

- 51.1 The Employer shall make advance payment (not to be paid less than two installments except in special circumstances for which the reason to be Recorded in writing) to the Contractor of the amounts stated in the Contract Date by the date stated in the Contract Date, against provision by the Contractor of an Unconditional Bank Guarantee in a form and by a bank acceptable to the Employer in amounts and currencies equal to be at least 110% of the advance payment. The guarantee shall remain effective until the advance payment has been repaid, but the amount of the guarantee shall be progressively reduced by the amounts repaid by the Contractor. The Mobilization advance would be deemed as interest bearing advance at an interest rate of 10 % to be compounded, quarterly.
- 51.2 The Contractor is to use the advance payment only to pay for Equipment, plant and Mobilization expenses required specifically for execution of the Works. The Contractor shall demonstrate that advance payment has been used in this way by supplying copies of invoices or other documents to the engineer.

51.3 The advance payment shall be repaid by deduction proportionate amount from payments otherwise due to the Contractor, following the schedule of completed percentages of the Works on a payment basis. No account shall be taken of the advance payment or its repayment in assessing valuations of work done, variations, price adjustments, Compensation Events, or Liquidated damages.

51.4 Deleted

52. Securities

52.1 The performance Security (including additional security for unbalanced bids) shall be provided to the Employer no later than the date specified in the Letter of Acceptance and shall be issued in an amount and form and by a bank or surety acceptable to the Employer, and denominated in Indian Rupees. The performance Security shall be valid until a date 60 days from the date of expiry of Defects Liability Period and the additional security for unbalanced bids shall be valid until a date 28 days from the date of issue of the certificate of completion.

53. Deleted

54. Cost of Repairs.

54.1 Loss or damage to the Works or Materials to be incorporated in the Works between the Start date and the end of Defects Correction periods shall be remedied by the Contractor at the Contractor's cost if the loss or damages arises from the Contractor's acts or omissions.

E. FINISHING THE CONTRACT

55. Completion

55.1 The Contractor shall request the Engineer to issue a Certificate of Completion of the works and the Engineer will do so upon deciding that the work is completed.

56. Taking Over

56.1 The Employer shall take over the Site and the Works within seven days of the Engineer issuing a certificate of Completion.

57. Final Account

57.1 The Contractor shall supply to the Engineer a detailed final account of the total amount that the Contractor considers payable as full and final settlement of all claims under the Contract for items before the end of the Defects Liability Period. The Engineer shall issue a Defect Liability Certificate and certify any final payment that is due to the Contractor within 56 days of receiving the Contractor's account if it is correct and complete. If it is not, the Engineer shall issue within 56 days a schedule that states the scope of the corrections or additions that are necessary. If the Final Account is still unsatisfactory after it has been resubmitted, the Engineer shall decide on the amount payable to the Contractor and issue a payment certificate, within 56 days of receiving the Contractor's revised account.

57.2 If reversal in characteristic of tender (L1 becoming L2) on account of excesses and savings in final account is observed, the Engineer/Employer shall be at liberty to restrict the final payment of BOQ items to the lowest amount evaluated of the bids considering the final quantities and the rates quoted including the rebates if any. Payment of variation items shall however be made at the rates approved by the Employer, within 90 days from the physical completion of work.

58. Operating and Maintenance Manuals

58.1 If "as built" drawings and/or operating and maintenance manuals are required, the Contractor shall supply them by the dates stated in the Contract data.

58.2 If the Contractor does not supply the Drawings and/or manuals by the dates stated in the Contract data, or they do not receive the Engineer's approval, the Engineer shall withhold the amount stated in the Contract Data from payments due to the Contractor.

59. Termination

59.1 The Employer or the Contractor may terminate the Contract if the other party causes a fundamental breach of the Contract.

59.2 Fundamental breaches of Contract include, but shall not be limited to the following:

1. The contractor stops work for 28 days when no stoppage of work is shown on the current programme and the stoppage has not been authorized by the Engineer
2. The Engineer instructs the Contractor to delay the progress of the Works and the instructions is not withdrawn within 28 days;
3. The Employer or the Contractor is made bankrupt or goes into liquidation other than for a reconstructions or amalgamation
4. A payment certified by the Engineer is not paid by the Employer to the Contractor within 56 days of the date of the Engineer's certificate
5. The Engineer gives Notice that failure to correct a particular Defect is a fundamental breach of Contract and the Contractor fails to correct it within a reasonable period of time determined by the Engineer;
6. The Contractor does not maintain a security which is required;
7. The Contractor has delayed the completion of works by the number of days for which the maximum amount of liquidated damages can be paid as defined in the Contract data; and
8. If the Contractor, in the judgment of the Employer has engaged in corrupt or fraudulent practices in competing for or in executing the Contract.

For the purpose of this paragraph: "corrupt practice" means the offering, giving, receiving or soliciting of anything of value to influence the action of a public official in the procurement process or in contract execution. "Fraudulent practice" means a misrepresentation of facts in order to influence a procurement process or the execution of a contract to the detriment of the borrower, and includes collusive practice among Bidders (prior to or after bid submission) designed to establish bid prices at artificial non-competitive levels and to deprive the Borrower of the benefits of free and open competition.

59.3 When either party to the Contract gives notice of a breach of contract to the Engineer for a cause other than those listed under Sub Clause 59.2 above, the Engineer shall decide whether the breach is fundamental or not.

59.4 Notwithstanding the above, the employer may terminate the Contract for convenience.

60. Payment upon Termination

60.1 If the Contract is terminated because of a fundamental breach of Contract by the Contractor, the Engineer shall issue a Certificate for the value of the work done less advance payments received up to the date of the issue of the

certificate, less other recoveries due in terms of the contract, less taxes due to deducted at source as per applicable law and less the percentage to apply to the work not completed as indicated in the Contract data. Additional Liquidated Damages shall not apply. If the total amount due to the Employer exceeds any payment due to the Contractor the difference shall be a debt payable to the Employer.

60.2 If the Contract is terminated at the Employer's convenience or because of a fundamental breach of Contract by the Employer, the Engineer shall issue a certificate for the value of the work done, the cost of balance material brought by the contractor and available at site, the reasonable cost of removal of equipment, repatriation of the Contractor's personnel employed solely on the works, and the Contractor's cost of protecting and securing the Works and less advance payment received up to the date of the certificate, less other recoveries due in terms of the contract and less taxes due to deducted at source as per applicable law.

61. Property

61.1 All materials on the Site, Plant Equipment, Temporary Works and Works are deemed to be property of the Employer, if the Contract is terminated because of a Contractor's default.

62. Release from Performance

62.1 If the Contract is frustrated by the outbreak of war or by any other event entirely outside the control of either the Employer or the Contractor the Engineer shall certify that the Contract has been frustrated. The Contractor shall make the Site safe and stop work as quickly as possible after receiving this certificate and shall be paid for all work carried out before receiving it and for any work carried out afterwards to which commitment was made.

F. SPECIAL CONDITIONS OF CONTRACT

63. LABOUR

The Contractor shall, unless otherwise provided in the Contract, make his own arrangements for the engagement of all staff and labour, local or other, and for their payment of housing, feeding and transport.

The Contractor shall, if required by the Engineer, deliver to the Engineer a return in detail, in such form and at such intervals as the Engineer may prescribe, showing the staff and the numbers of the several classes of labour from time to time employed by the Contractor on the site and such other information as the Engineer may require.

64. COMPLIANCE WITH LABOUR REGULATIONS

During continuance of the contract, the Contractor and his sub-contractor shall abide at all times by all existing labour enactments and rules made thereunder, regulations, notification and bye laws of the State or central Government or local authority and any other labour law (including rules), regulations, bye laws that may be passed or notifications that may be issued under any labour law in future either by the State or the Central Government or the local authority. Salient features of some of the major labour laws that are applicable to the construction industry are given below. The Contractor shall keep the Employer indemnified in case any action is taken against the Employer by the competent authority on account of contravention of any of the provisions of any Act or rules made thereunder, regulations or notifications including amendments. If the Employer is caused to pay or reimburse, such amounts as may be necessary to cause or observe, or for observance of the provisions stipulated in the notifications/bye laws/Acts/Rules/regulations including amendments, if any, on the part of the Contractor, the Engineer/employer shall have the right to deduct any money due to the Contractor including his amount of performance security. The Employer/Engineer shall also have the right to recover from the Contractor any sum required or estimated to be required for making good the loss or damage suffered by the Employer.

The employees of the Contractor and the Sub-Contractor in no case shall be treated as the employees of the Employer at any point to time.

SALIENT FEATURES OF SOME MAJOR LABOUR AND OTHER LAWS APPLICABLE TO ESTABLISHMENTS ENGAGED IN BUILDING AND OTHER CONSTRUCTIONS WORK

- A) **Workmen Compensation Act 1923** :- The Act provides for compensation in case of injury by accident arising out of and during the course of employment.
- B) **Payment of Gratuity Act. 1972** :- Gratuity is payable to an employee under the Act on satisfaction of certain conditions on separation if an employee has completed 5 years service or more on death, the rate of 15 days wages for every completed year of service. The Act is applicable to all establishments employing 10 or more employees.
- C) **Employees P.F. and Miscellaneous Provision Act 1952:-** The Act Provides for monthly contributions by the employer plus workers @ 10% or 8.33% The benefits payable under the Act are :
1. Pension or family pension on retirement or death, as the case may be.
 2. Deposit linked insurance on the death in harness of the worker.
 3. Payment of P.F. accumulation on retirement/death etc.
- D) **Maternity Benefit Act 1951** :- The Act provides for leave and some other benefits to women employees in case of confinement or miscarriage etc.
- E) **Contract Labour (Regulation & Abolition) Act 1970** : The Act provides for certain welfare measures to be provided by the Contractor to contract labour and in case the Contractor fails to provide, the same are required to be provided, by the Principal Employer by Law. The principal Employer is required to take Certificate of Registration and the Contractor is required to take license from the designated Officer. The Act is applicable to the establishments or Contractor of Principal Employer, if they employ 20 or more contract labour.
- F) **Minimum Wages Act 1948 :-** The Employer is supposed to pay not less than the Minimum Wages fixed by appropriate Government as per provisions of the Act, if the employment is a scheduled employment. Construction of Building, Roads, Runways are scheduled employment.
- G) **Payments of wages Act 1936:-** It lays down as to by what date the wages are to be paid, when it will be paid and what deductions can be made from the wages of the workers.
- H) **Equal remunerations Act 1979** :- The Act provides for payment of equal wages for work of equal nature to Male and Female workers and for not making discrimination against female employees in the matter of transfer, training and promotions etc.
- I) **Payments of Bonus Act 1965** :- The Act is applicable to all establishments employing 20 or more employees. The Act provides for payments of annual bonus subject to a minimum of 8.33% of wages and maximum of 20 % of wages to employees drawing Rs. 3500/- per month or less. The bonus to be paid to employees getting Rs, 2500/- per month or above Rs. 3500/- per month shall be worked out by taking wages as Rs. 2500/- per month only. The Act does not

apply to certain establishments. The newly set-up establishments are exempted for five years in certain circumstances. Some of the State Governments have reduced the employment size from 20 to 10 for the purpose of applicability of this Act.

- J) **Industrial Disputes Act 1947** :- The Act lays down the machinery and procedure for resolutions of Industrial disputes, in what situations a strike or lock-out becomes illegal and what are the requirements for laying off or retrenching the employees or closing down the establishment.
- K) **Industrial employment (standing Orders) Act 1946** :- It is applicable to all establishments employing 100 or more workmen (employment size reduced by some of the State and Central Government to 50). The Act provides for laying down rules governing the conditions of employment by the Employer on matters provided in the Act and get the same certified by the designated Authority.
- L) **Trade Unions Act 1926**:- The Act lays the procedure for registration of trade unions of workmen and employers. The Trade Unions registered under the Act have given certain immunities from civil and criminal liabilities.
- M) **Child Labour (Prohibition & Regulation Act 1986** :- The Act prohibits employment of children below 14 years of age in certain occupations and process and provides for regulation of employment of children in all other occupations and processes. Employment of Child labour is prohibited in Building and Construction Industry.
- N) **Inter - State Migrant workmen's (Regulation of Employment & Conditions of service) Act 1979**:- The Act is applicable to an establishment which employs 5 or more inter-state migrant workmen through an intermediary (who has recruited workmen in one state for employment in the establishment situated in another state).The inter-state migrant workmen, is an establishment to which this Act becomes applicable, are required to be provided certain facilities such as housing, medical aid, traveling expenses from home upto the establishment and back, etc.
- O) **The Building and Other Construction workers (Regulation of employment and Conditions of Service) Act 1996 and the Cess Act of 1996**:- All the establishments who carry on any building or other constructions work and employ 10 or more workers are covered under this Act.
All such establishments are required to pay cess at the rate not exceeding 2% of the cost of construction as may be modified by the government. The Employer of the establishment is required to provide safety measures at the Building or construction work and other welfare measures, such as canteens, First Aid facilities, Ambulance, Housing accommodations for workers near the workplace etc. The Employer to whom the Act applies has to obtain a registration certificate from the Registering Officers appointed by the Government.

- P) **Factories Act 1948 :-** The Act lays down the procedure for approval of plans before setting up a factory, health and safety provisions, welfare provisions, working hours, annual earned leave and rendering information regarding accidents or dangerous occurrences to designated authorities. It is applicable to premises employing 10 persons or more with aid of power or 20 or more persons without the aid of power engaged in the manufacturing process.
- Q) **Royalty charges-**The contractor shall pay the royalty to the competent authority as per rule. The **royalty** charges paid shall be borne by the contractor and shall not be reimbursed by the Employer.
- R) **Following Pollution control Acts and amendments made thereof from time to time shall be applicable.**
1. Water (Preservation and control of Pollution) Act, 1974
 2. Air (Prevention and Control of Pollution Act 1981
 3. Environmental (Protection) Act 1986

The contractor must commit to adopting Environmental management plan for best energy use, waste management, the reduction of pollution as in EMS (Environmental Management system)ISO-14001-2015

65. ARBITRATION (GCC Clause 24)

The procedure for arbitration will be as follows: -

- 24.1 If the Contractor is of the view that a decision taken by the Engineer was either outside the authority given to the Engineer by the Contract or that the decision was wrongly taken, the decision shall be referred to Director, GNLU, **Gandhinagar** within 14 days of the notification of the Engineer's decision. If the issue is not resolved, any party can refer the matter for conciliation within 15 days from the decision given by the Engineer.
- 24.2(a) If any of the parties is not satisfied with the decision of the Registrar **GNLU, Gandhinagar**, both the parties have to refer to the Director, GNLU, Gandhinagar for the conciliation process.

If the dispute is not resolved through the conciliation process, contractor may refer the dispute to Gujarat Public Works Contract Dispute Arbitration Tribunal. If the Contractor fails to refer a claim / dispute to the Higher Authority within 14 days of the notification of the Engineer's decision, the Contractor shall not be entitled to any additional payment/claim if he doesn't follow the above sequence in stipulated time. However, during such period, he would not stop the work in any case.

SECTION - 4
CONTRACT DATA

CONTRACT DATA

Clause Reference With
respect To section 3

Item marked "N/A" do not apply to this Contract.

1. The Employers is [CL.1.1]
Name: Registrar Gujarat National law University
Address: Gujarat National Law University, Attalika Avenue, Knowledge
Koba, Gandhinagar.

Name of authorized Representative (will be intimated later)
2. The Engineer is Consulatant, Project Management,

Name of Authorized Representative: Shri S.C.Rathod
3. The Defects Liability Period is **12 months** from the date of [CL.1.1&33]
completion.
4. The Start Date shall be **1st** days for the date of issue of the Notice [CL.1.1]
to proceed with the work.
5. The Intended Completion Date for the whole of the works is [CL.1.1,17&2]
06 Months after start of work with the following milestones:
Milestone dates: [CL.2.2& 49.1]
Physical works to be completed Period from the start date
Milestone 1 i.e. 25 % 45 days.
Milestone 2 i.e. 50 % 91 days.
Milestone 3 i.e. 75 % 135 days.
Milestone 4 i.e. 100 % 182 days.
6. The Site is located at Gujarat National Law University, Attalika Avenue, [CL.1.1]
Knowledge corridor, Koba, Gandhinagar
7. The name and identification number of the Contract is: As per tender [CL.1.1]
notice
8. The works consist of Providing and fixing Chain link fencing around Football [CL.1.1]
ground, Punit Van and Academic building with items as per B.O.Q. The works
shall, inter alia, include the following, as Specified or as directed

(C) Other Items

- Any Other Items as required to fulfill all contractual obligations as per the Bid documents. [CL.1.1]
10. The following documents also form part of the Contract:
As per clause 2-3
11. The law which applies to the Contract is the law of Union of India [CL.2.3(9)]
[CL.3.1]
12. The language of the Contract documents is English [CL.3.1]
13. Limit of subcontracting 25% of the Initial Contract Price [CL.7.1]
14. The Schedule of Other Contractors [CL.8]
15. The Schedule of Key Personnel As per Annex – II to Section I [CL.9]
16. The minimum insurance cover for physical property, injury and death is Rs. 5 lakhs per occurrence with the number of occurrences limited to four. After each occurrence, the contractor will pay an additional premium necessary to make insurance valid for four occurrences always. [CL.13]

17. Site Investigation report [CL.14]
18. The Site Possession dates shall be 2nd day from Letter of Acceptance [CL.21]
19. The period for submission of programme for approval of the engineer shall be 21 days from the issue of Letter of Acceptance. [CL. 27.1]
20. The period between program updates will be 01 days. [CL.27.3]
21. The amount to be withheld for late submission of an updated programme shall be Rs 0.50 lakhs [CL. 27.3]
22. The following events shall also be Compensation Events [CL. 44]
- Substantially adverse ground conditions encountered during the course of execution of work not provided for in the bidding document.
- (i) Removal of underground utilities detected subsequently
 - (ii) Significant changes in classification of soil requiring additional mobilization by the contractor, e.g. ordinary soil to rock excavation,
 - (iii) Removal of unsuitable material like marsh, debris dumps, etc. not caused by the contractor.
 - (iv) Artesian conditions
 - (v) Seepage, erosion landslide
 - (vi) River training requiring protection of permanent work
 - (vii) Presence of historical, archeological or religious structures, monuments interfering with the works
 - (viii) Restriction of access to ground imposed by civil, judicial, or military authority
23. The currency of the Contract is Indian Rupees [CL. 46]
25. The proportion of payments retained (retention money) shall be 6% from each bill subject to a maximum of 5% of final contract price. {CL. 48}
26. Amount of Liquidated damages for delay in completion of works For Whole of work {CL.49} (1/2000)th of the Initial contract price, rounded off to the nearest Thousand, per day. For sectional Completion (wherever specified In item 6 of Contract data) (1/2000)th of initial contract price for #5 km Section, rounded off to the nearest Thousand per day.

27. Maximum limit of liquidated damages For delay in completion work 10 percent of the Initial Contract Price rounded off to the nearest thousand {CL. 49}
28. Deleted
29. Maximum limit of bonus for early Completion of work **Deleted**
30. The amount of the advance payment are: {CL. 51 & 52}

#Nature of Advances

		Amount (Rs.)	Conditions to Be fulfilled
i	Mobilization	10% of the contract Price	On submission of unconditional Bank Guarantee. (to be drawn before the end of 20% of the contract period). The contractor may furnish four bank guarantees of 2.5 % of each valid for the full period.
ii	Equipment	90% for new and 50% of depreciated value for old equipment. Total amount will be subject to a maximum of 5% of the Contract Price	After equipment is brought to site (provided the Engineer is satisfied That the equipment is required for performance of the contract) and on submission of unconditional Bank Guarantee for amount of advance
iii	Secured Advance for Non-persish able material Brought to site	Deleted	

(The advance payment will be paid to the Contractor no later than 28 days after fulfillment of the above conditions).

31. Repayment of advance payment for mobilization and equipment {CL. 51.3}

The advance loan shall be repaid with percentage deduction from the interim payments certified by the Engineer under the Contract. Deduction shall commence in the next Interim Payment Certificate following that in which the

total of all such payments to the Contractor has reached not less than 20 percent of the Contract Price or 6 (six) months from the date of payment of first installment of advance, whichever period concludes earlier, and shall be made at the rate of 20 percent **(collectively for both Mobilization Advance and Equipment Advance)** of the amounts of all Interim Payment Certificate until such time as the loan has been repaid, always provided that the loan shall be completely repaid prior to the expiry of the original time for completion pursuant to Clause 17 and 28.

32. Deleted
33. The securities shall be for the following minimum amounts equivalent {CL. 52}
As a percentage of the Contract Price:
Performance Security for 5 percent of contract price plus Rs. (to be decided after evaluation of the bid) as additional security in terms of ITB Clause 29.5

The standard form of Performance security acceptable to the Employer shall be an unconditional Bank Guarantee of the type as presented in Section 8 of the Bidding Documents.

34. The Schedule of Operating and maintenance Manuals.....N/A. {CL. 58}
35. The date by which “as- built” drawings (in scale as directed) in 2 sets {CL. 58} are required within 28 days of the issue of certificate of completion of the whole or section of the work, as the case may be.
36. The amount to be withheld for failing to supply “as built” drawings {CL. 58} by the Date required is Rs 5.0 Lakhs.
37. The following events shall also be fundamentals breach of contract: {CL.59.2}
“The Contractor has contravened Sub- clause 7.1 and Clause 9 of GCC”
38. The percentage to apply the value of the work not completed representing {Cl 60} the Employer’s additional cost for completing the Works shall be 20 percent.

VOLUME-II

SECTION - 5

TECHNICAL SPECIFICATION

Name_of_work: PROVIDING AND FIXING CHAINLINK FENCING AROUND FOOTBALL GROUND, PUNIT VAN AND ACEDIMIC BLOCK

TECHNICAL SPECIFICATION

1. Item No. 1

Excavation for foundation in all sorts of soil including yellow, sandy, gravelly soil, soft murrum & hard murrum etc. including depositing the excavated stuff in uniform layers in banks or as and where directed etc. complete for lead upto 1 km and all lift.

2. *Scope of Work:*

The scope of work includes excavation of footing for chain link fencing.

3. *Excavation for foundation:*

- a) Excavation of the foundation can be under taken after clearing the site. The excavation shall be done according to the dimension & shown on the working drawing or as per the direction of Engineer-in-charge.
- b) The excavated stuff shall be used in filling the trenches and plinth or leveling the canal embankment in layers including ramming and watering etc. The balance of the excavated quantity shall be removed by the contractor from site of work to a place as directed.
- c) Tolerance: Finished section shall have a neat and smooth profile as per designed section. Over cut and Undercut shall not exceed 1.00 cm.
- d) The excavation for foundation shall be carried out in true line and level and shall have the width and depth as shown in the drawings or as directed. The contractor shall do the necessary shoring and strutting of slope to a safe angle, if necessary at his own cost. The bottom of the excavated area shall be leveled both longitudinally and transversely as directed. No earth filling shall be allowed to bring it to level.
- e) Over excavation: Over excavation beyond the tolerance limits carried out by the contractor for any purpose or reason shall be rectified at his expense by filling and computing using the material as directed by the representative of Engineer-in-charge.

4. *Measurement & payment*

- a) No extra rate shall be payable for excavation below designed depth shown on the drawings. No claim for extra rate shall be entertained for any excavation that may be required to be done for widening or deepening the foundations consequent upon lowering of foundation below the level shown on the drawings. The works so done will be paid at the tendered rates of the item
- b) Payment shall be made at the Unit contract rate per cubic meter for the quantity excavated limit to the dimension shown in the drawing with leads and lifts specified in

the item. The rate also includes cost of all labours, machinery and incidental expenses for carrying out the work in accordance with the specifications.

2. Item No :2

Providing and laying machine mixed machine vibrated Plain Cement Concrete 1:3:6 (1 Cement : 3 Coarse sand :6 graded stone aggregate 40 mm nominal size of approved quality on base of wall , compacting , curing and dewatering where required as per the drawing and to the satisfaction of the Engineer in charge.

3. Item No :3

Providing and laying Brick masonry in CM 1:6 (1 Cement : 6 Coarse Sand) proportion for foundation and super structure with best Quality approved bricks crushing strength not less than 40 kg/ cm² including cost and conveyance of all other materials at site, lead and lift & conveyance of all height and depth, raking of joints curing & all other operational & labour charges etc. complete.

4. Item No : 4

Providing and laying average 25 mm thick red Dholpur stone of approved quality, selected and sorted for uniform colour, around the wall as per drawing at all heights in required sizes up to 60 cm as per design with normal pattern (square, Rectangular) as per drawing, including cement mortar bedding 1:6 proportion in required thickness, jointed grey cement and colour pigment as specified. Three or more coats of polishing , curing etc. complete up to the satisfaction of Engineer in charge.

Dholpur Stone Slab

. Dholpur stone slab shall be of best quality as approved by the Engineer-in-charge The stone slab shall be without any veins, cracks, and flaws The stone slab shall be even sound and durable regular in shape and of uniform colour. The size of the stone shall be as specified in the item or detailed drawing or as approved by the Engineer-in-charge The thickness of the stone shall be as specified in the item of work with the permissible tolerance of plus or minus 2 mm. The provision in respect of polishing as for polished kota stone shall apply to polished Dholpur stone also. All angles and edges of the face of the stone slab shall be finely chiseled or polished as specified in the item of work and all the four edges shall be machine cut All angles and edges of the stone slab shall be true and plane

The sample of stone shall be got approved by the Engineer-in-charge for a particular work It shall be ensured that the stones to be used in a particular work shall not differ much in shade or tint from the approved sample

5. Item No:5

Providing and erecting chain link jail, GI wire of 6 SWG with minimum 40 microns coating of Zinc & fabrication of mesh of 2" x 2" with approx. weight 13.67kg/Sq. Mtr at 2m interval with M.S. Angle frame of size 50x50x6 mm fixed with MS flat 32 x6mm on all sides and diagonal and supported on MS Box pipe size 50 x 50 having 20mm thick as per drawing, including all cost of material, fabrication, erection, nut ,bolts

and painting with two coats of oil paint including one coat of primer etc complete as per drawing and as directed.

1. SCOPE:-

The specification covers supply (including fabrication) providing & fixing of Chain link fencing using MS pipe , Ms angle & GI wire Mesh chain link For the safety aspects, to cover covering the Football ground, Punit van and behind Academic Building. A chain link fencing is to be fabricated from MS pipe of square hollow section (SHS), MS angle, MS Flat & GI wire as per the design & drawing and to be provided/fitted with vertical support posts of MS pipe of Square Hollow Section (SHS) embedded in wall as per drawing.

2. Quality / Standards of Material to be used

Basic material to be used for the fabrication of Chain Link Fencing which is to be supplied & provided is MS Pipe of Square Hollow Section (SHS), MS Angle, MS Flat & GI wire. Hence material should of standard quality of standard manufactured & name of manufactures to be specified in bid.

3. Size & Dimension of Material to be used

For Vertical Post: MS Box pipe of 50mm x 50mm x 2 mm. For Chain Link (inner) Frame: MS Angle of 50mm x 50 mm x 6mm having weight of 4.5kg/mtr. For Chain Link Mesh: GI wire of 6 SWG with minimum 40 microns coating of Zink & fabrication of mesh of 2" x 2" with approx. weight 6.42 kg/Sq. Mtr. MS Flat of size suitable to MS flat of 50 mm with Thickness of 6mm.

Miscellaneous material like Hinges, Aldraft, Nut Bolt & other sundary material of standard quality.

4. Dimensions for fabrication of Chain Link fencing of standard size as per drawing

Main (outer) Frame:

Main (outer) Frame should be fabricated from MS angle of 50mm x 50mm x 6mm as per drawing.

Size: Height: 2000 mm

Width: 2000mm

Installation i.e. fitting of Chain link Fencing at site:

Supplier has to fabricate all the section of complete chain link fencing as per drawing, dimension specified as above as well as per instructions of Engineer in charge and as per site requirement and installation. Prior to installation / fixing at site, all the MS parts should be applied two coats of red oxide. Main vertical posts should be grouted / fitted in the C.C. wall in such a way that the fencing frame should remain 100mm above from top of C.C. wall. Main vertical posts shall be anchored with existing parapet wall of bridge or adjacent component by clamping. While main post shall be anchored on top of the parapet wall along the canal by anchor bolt.

General Condition for Supply and Providing Chain Link Fencing

Space between Vertical post & main frame should not be more than 60mm.

Fencing panel height should not be less than 1100mm.

Chain link mesh is to be fixed in the frame of 50 x 50 x 6mm MS Angle frame supported with 50 x50 x2 mm Box pipe as per drawing in good quality of welding.

All the fabrication work should be done with good quality of welded & it should be free from sharp edges, concern & unevenness of surface. It should also with good finishing & decent look up to the satisfaction of the Engineer in charge.

The drawing & dimension (except height) are for standard & normal location. However, it may be as per site situation. Hence supplier has to approach concern Engineer in charge, joint visit for each location & record the dimensions according to site situation and accordingly has to fabricate, Supply & fixing the chain link fencing as per the instruction of Engineer in charge.

The drawing shall not absolve the supplier from his liability for insure appropriate dimensions & to supply & providing accordingly as per the site situation & instruction of Engineer in charge.

Fitting of complete chain link fencing panel with vertical post should be done with 50 mm MS flat with thickness of 6mm and Nut Bolt of 2" x 3/4" size as per drawing. It should be in such that both side & rear side, with tight fitting by Nut-Bolts whereas front side, it should be slightly loose fitted so that it can work as hinges.

1. **General:**

1. The materials required for work of painting work shall be obtained directly from approved manufacturers or approved dealer and brought to the site in maker's drums, kegs etc. with seal unbroken.
2. All materials not in actual use, shall be kept properly protected, lids of containers shall be kept closed and surface of paint in open or partially open containers covered with a thin layer of turpentine to prevent formation of skin. The materials which have become stale or flat due to improper and long storage shall not be used. The paint shall be stirred thoroughly in its container before pouring into small containers. While applying also the paint shall be continuously stirred in smaller container. No left over paint shall be put back into stock tins. When not in use, the containers shall be kept properly closed.
3. If for any seasons, thinning is necessary, the brand of thinner recommended by the manufacturer shall be used.
4. The surface to be painted shall be thoroughly cleaned and dusted. All rust, dirt and grease shall be thoroughly removed before painting is started. No painting on exterior or other exposed parts of the work shall be carried out in wet, damp or otherwise unfavorable weather and all the surfaces shall be thoroughly dry before painting work is started.

Painting :

Material

- i. The ready mixed primer, brushing red shall conform to I.S. 102-1962.
- ii. The thinner (linseed oil) shall conform to I.S. 75-1973. If for any reason, thinning is necessary in case of ready mix paint the brand of thinner recommended by manufacture shall be used.
- iii. The enamel paint shall satisfy in general requirements as mentioned in specification of oil paints. Enamel paint shall conform to I.S. 2933-1975.

2. **Preparation of Surfaces:**

The surfaces painting shall be cleaned of all rust, scale, dirt and other foreign matter sticking to it with wire brushes, steel wool, scrapers, sand paper etc. This surface shall then be wiped

finally with mineral turpentine which shall also remove grease and perspiration of hand marks. The surface shall then be allowed to dry.

3. **Application:**

1. After the preparation of the surface, the priming coat shall be applied immediately. The brushing operations are to be adjusted to the spreading capacity advised by the manufacturer of the particular primer. The paint shall be applied evenly and smoothly by means of crossing and laying off. The crossing and laying off consists of covering the area over with paint, brushing alternately in opposite directions, two or three times and then finally brushing lightly in a direction at right angles to the same. In this process, no brush marks shall be left after the laying off is finished. The full process of crossing and laying off wall constitute one coat
2. During painting, every time, after the priming coat has been worked out of the brush bristles or after the brush has been unloaded, the bristles of the brush shall be opened up by striking the brush against portion of the unpainted surface with the end of the bristles, held at right angles to the surface, so that bristles thereafter will collect the correct amount of paint when dipped again in to a paint container The prima/y coat shall be allowed to dry completely before painting is started.
3. No hair marks from the brush or clogging at pain puddles in the corner of panels angles of molding etc. shall be left on the work.
4. Special care shall be taken while painting over bolts, nuts, rivets, overlaps etc.
5. The container when not in use shall be kept close and free from air so that paint does not thickness and also shall be kept guarded from dust.
6. No payment shall be made for weight of screws, bolts nuts etc. only weight of grill shall be paid.
7. The rate shall be for a unit of one sq. metre.

5. **Quality of material:**

As the major material is a steel item, the material like MS Pipe, MS Angle, MS Flat n MS Box pipe & GI wire must be as per relevant IS & bidder has to confirm regarding the same.

The entire job will be prepared with proper care, welding and fine finish to give decent aesthetic look.

Major material is of steel items if found inferior a lot of material will be rejected.

6. **Mode of measurements & payment:**

The rate includes the cost of all labour and materials, tools and plant etc. required for satisfactory completion of this item.

The payment for the item shall be made at unit tendered rate on running **Meter** basis.

VOLUME-III

SECTION - 6

FORM OF BID

FORM OF BID

Description of the Works: Tender for Providing and fixing Chain link fencing around Football ground, Punit Van and Academic building.

BID

To : The Registrar
Gujarat National Law University
Attalika Avenue, Knowledge Corridor, Koba,
Koba (Sub P. O.), Gandhinagar - 382426 (Gujarat), INDIA.

1. We offer to execute the Works described above and remedy any defects therein in conformity with the conditions of Contract, specification, drawings, Bill of Quantities and Addenda for the sum (s) of

(-----)

2. We undertake, if our Bid is accepted, to commence the Works as soon as is reasonably possible after the receipt of the Engineer's notice to commence, and to complete the whole of the Works in the Contact within the time stated in the document.
3. We agree to abide by this Bid for the period of 120 Days from the date fixed for receiving the same, and it shall remain binding upon it and may be accepted at any time before the expiration of that period.
4. Unless and until a formal Agreement is prepared and executed this Bid, together with your written acceptance thereof, shall constitute a binding contract between us.
5. We understand that you are not bound to accept the lowest or any tender you may receive.

Dated this ----- day of -----20

Signature ----- in the capacity of -----

----- duly authorized to sign bids for and on behalf of -----

(in block capitals or typed)

Address

Witness

Address

Occupation

SECTION - 7
BILL OF QUANTITIES

BILL OF QUANTITIES

Preamble

1. The bill of Quantities shall be read in conjunction with the Instructions to Bidder, Conditions of Contract, Technical Specifications and Drawings.
2. The quantities given in the Bill of Quantities are estimated and provisional, and are given to provide a common basis for bidding. The basis of payment will be the actual quantities of work ordered and carried out, as measured by the Contractor and verified by the Engineer and valued at the rates and prices tendered in the priced Bill of Quantities, where applicable, and otherwise at such rates and prices as the Engineer may fix within the terms of the Contract.
3. The rates and prices tendered in the priced Bill of Quantities shall, except in so far as it is otherwise provided under the Contract, include all constructional plant, layout, supervision, materials, erection, maintenance, insurance, profit, taxes and duties, together with all general risks, liabilities and obligations set out or implied in the Contract.
4. The rates and prices shall be quoted entirely in Indian Currency.
5. A rate or prices shall be entered against each item in the Bill Quantities, whether quantities are stated or not. The cost of Items against which Contractor has failed to enter a rate or price shall be deemed to be covered by other rates and prices entered in the Bill of Quantities (in case of Item rate contract).
6. The whole cost of complying with the provisions of the Contract shall be included in the items provided in the priced Bill of Quantities, and where no Items are provided the cost shall be deemed to be distributed among the rates and prices entered for the related items of Work.
7. General direction and descriptions of work and materials are not necessarily repeated or summarized in the Bill of Quantities. References to the relevant sections of the contract documentation shall be made before entering rates or prices against each item in the Bill of Quantities.
8. The method of completed work of payment shall be in accordance with the specification for Road and Bridge works. For building works specifications for building are to be followed.
9. Errors will be corrected by the Employer for any arithmetic errors pursuant to **Clause 29** of the Instructions to Bidder.
10. Rock is defined as all materials which, in the opinion of the Engineer, required blasting, or the use of metal wedges and sledgehammers, or the use of compressed air drilling for its removal, and which cannot be extracted by ripping with a tractor of at least 150 kw with a single rear mounted heavy duty ripper.

BILL OF QUANTITIES

Name of Work: Tender for Providing and fixing Chain link fencing around Football ground, Punit Van and Academic building

Sr No	Description of Item (with brief specification and reference to book of specifications)	Tender Qty	Unit	Rate	Total
1	<p><u>Item No: 1</u> Excavation for foundation in all sorts of soil including yellow, sandy, gravelly soil, soft murrum & hard murrum etc. including depositing the excavated stuff in uniform layers in banks or as and where directed etc. complete for lead upto 1 km and all lift.</p>	91.125	Cum		
2	<p><u>Item No: 2</u> Providing and laying machine mixed machine vibrated Plain Cement Concrete 1:3:6 (1 Cement : 3 Coarse sand :6 graded stone aggregate 40 mm nominal size of approved quality on base of wall , compacting , curing and dewatering where required as per the drawing and to the satisfaction of the Engineer in charge.</p>	30.375	Cum		
3	<p><u>Item No: 3</u> Providing and laying Brick masonry in CM 1:6 (1 Cement : 6 Coarse Sand) proportion for foundation and super structure with best Quality approved bricks crushing strength not less than 40 kg/ cm² including cost and conveyance of all other materials at site, lead and lift & conveyance of all height and depth, raking of joints curing & all other operational & labour charges etc. complete</p>	155.25	Cum		
4	<p><u>Item No: 4</u> Providing and laying average 25 mm thick red Dholpur stone of approved quality, selected and sorted for uniform colour, around the wall as per drawing at all heights in required sizes up to 60 cm as per design with normal pattern (square, Rectangular) as per drawing, including cement mortar bedding 1:6 proportion in required thickness, jointed grey cement and colour pigment as specified. Three or more coats of polishing , curing etc. complete up to the satisfaction of Engineer</p>	1350	Sq.mt		

5	<p>Item No: 5 Providing and erecting chain link jail, GI wire of 6 SWG with minimum 40 microns coating of Zink & fabrication of mesh of 2" x 2" with approx. weight 13.67kg/Sq. Mtr at 2m interval with M.S. Angle frame of size 50x50x6 mm fixed with MS flat 32 x6mm on all sides and diagonal and supported on MS Box pipe size 50 x 50 as per drawing, including all cost of material, fabrication, erection, nut ,bolts and painting with two coats of oil paint including one coat of primer etc complete as per drawing and as directed.</p>	675	Rmt		
				Grand Total	

(A) Total Tendered Amount

(B) Rebate on above tendered amount (if any) % (in figure)

..... (in words).....

(C) Net Tendered Amount (A-B) (in figure)

(in words).....

#

1. The Contractor shall exhibit a board with brief details of work as directed by the Engineer-In-Charge for which no extra payment shall be made.
2. The labour cess will be deducted as per prevailing rules i.e. 1% of the work done.
3. GST and Income tax TDS will be deducted at a source while making payments of bills.
4. In all R.C.C. Items in Rate Analysis Standard Cement Consumption has been taken as per Govt. G.R. NO.: MIS102010/17/K1 Dated:30/07/2018 as stated in S.O.R. therefore in R.C.C. items where there is a change as per actual mix design the cost of difference of cement consumption have been deducted from the rate of original item at the rate of input rate mentioned in all the tender.

SECTION - 8
SECURITIES AND OTHER FORMS

BID SECURITY (BANK GUARANTEE)

WHEREAS, ----- (name of Bidder) (hereinafter called the "The Bidder") has submitted his bid Dated ----- (Date) for the construction of ----- (Name of Contractor hereinafter called "the Bid")

KNOW ALL PEOPLE by these presents that We ----- (name of Bank) of----- (name of country) having our registered office at ----- (hereinafter called "the bank") are bound unto ----- (name of Employer) (hereinafter called "The Employer") in the sum of ----- * for which payment well and truly to be made to the said Employer the Bank itself, his successors and assigns by these presents.

SEALED with the Common Seal of the said Bank this ----- day of -----20

THE CONDITIONS of these obligations are:

(1) If after Bid opening the Bidder withdraws his bid during the period of Bid validity specified in the Form of Bid;

Or

(2) If the Bidder has been notified of the acceptance of his bid by the Employer during the period of Bid Validity:

A Fails or refuses to execute the Form of Agreement in accordance with the Instructions to Bidders, if required; or

B. Fails or refuse to furnish the Performance Security, in accordance with the Instructions to Bidders; or

C. does not accept the correction of the Bid Price pursuant to Clause 27 (Correction of Errors)

We undertake to pay to the Employer up to the above amount upon receipt of his first written demand, without the employer having to substantiate his demand, provided that in his demand the Employer will note that the amount claimed by him is due to him owing to the occurrence of one or any of the three conditions, specifying the occurred conditions or conditions.

This Guarantee will remain in force up to and including the date ----- ** days after the deadline for submission of Bids as such the deadline is stated in the Instructions to Bidders or as it may be extended by the Employer, notice of which extension (s) to the Bank is hereby waived. Any demand in respect of this guarantee should reach the Bank not later than the above date

DATE -----

SIGNATURE-----

WITNESS -----

SEAL -----

(Signature, name and address)

* The Bidder should insert the amount of the guarantee in words and figures denominated in Indian Rupees. This figure should be the same as shown in Clause 16.1(Bid Security) of the Instructions to Bidders.

****45 days** after the **end of the validity period** of the Bid. Date should be inserted by the Employer before the Bidding documents are issued.

PERFORMANCE SECURITY

TO,

----- (Name of Employer)
----- (Address of Employer)

WHEREAS ----- (name and address of contractor) (hereafter called "the Contractor") has undertaken, in pursuance of Contracts No. ----- dates ----- to execute ----- (name of Contract and brief description of Works) (hereinafter called "The Contract")

AND WHEREAS it has been stipulated by you in the said Contract that the Contractor shall furnish you with a Bank Guarantee by a recognized bank for the sum specified therein as security for compliance with his obligation in accordance with the Contract.

AND WHEREAS we have agreed to give the Contractors such a bank Guarantee:

NOW THEREFORE we hereby affirm that we are the Guarantor and responsible to you on behalf of the Contractor, up to a total of ----- (amount of guarantee)* ----- (in words), such sum being payable in types and proportions of currencies in which the Contract prices is payable, and we undertake to pay you, upon your first written demand and without cavil or argument, any sum or sums within the limits of ----- (amount of guarantee) as aforesaid without your needing to prove or to show grounds or reasons for your demand for the sum specified therein.

We hereby waive the necessity of your demanding the said debt from the contractor before presenting is with the demand.

We further agree that no change or addition to or other modification of the terms of the Contract to of the Works to be performed thereunder or of any of the Contract documents which may be made between your and the Contractor shall in any way release us from any liability under this guarantee, and we hereby waive notice of any such charge, addition or modifications.

This guarantee shall be valid until 60 days from the date of expiring of the Defect Liabilities period.

Signature and Seal of the guarantor -----

Name of Bank -----

Address -----

Date -----

*An amount shall be inserted by the Guarantor, representing the percentage the Contract price specified in the Contract denominated in Indian Rupees.

ADDITIONAL PERFORMANCE SECURITY

[Clause 34.1. (A)]

TO,

----- (Name of Employer)
----- (Address of Employer)

WHEREAS ----- (Name and address of contractor) (hereafter called "The Contractor") has undertaken, in pursuance of Contracts No. ----- dates ----- to execute ----- (Name of Contract and brief description of Works) (hereinafter called "The Contract")

AND WHEREAS it has been stipulated by you in the said Contract that the Contractor shall furnish you with a Bank Guarantee by a recognized bank for the sum specified therein as security for compliance with his obligation in accordance with the Contract.

AND WHEREAS we have agreed to give the Contractors such a bank Guarantee:

NOW THEREFORE we hereby affirm that we are the Guarantor and responsible to you on behalf of the Contractor, up to a total of ----- (amount of guarantee) ----- (in words), such sum being payable in types and proportions of currencies in which the Contract prices is payable, and we undertake to pay you, upon your first written demand and without cavil or argument, any sum or sums within the limits of ----- (amount of guarantee) as aforesaid without your needing to prove or to show grounds or reasons for your demand for the sum specified therein.

We hereby waive the necessity of your demanding the said debt from the contractor before presenting is with the demand

We further agree that no change or addition to or other modification of the terms of the Contract to of the Works to be performed thereunder or of any of the Contract documents which may be made between your and the Contractor shall in any way release us from any liability under this guarantee, and we hereby waive notice of any such charge, addition or modifications.

This guarantee shall be valid until **28 days** from the project completion date.

Signature and Seal of the guarantor -----

Name of Bank -----

Address -----

Date -----

BANK GUARANTEE FOR ADVANCE PAYMENT

TO,

----- (Name of Employer)

----- (Address of Employer)

----- (Name of Contractor)

Gentlemen:

In accordance with the provisions of the Conditions of Contract, sub-clause 51.1 (“Advance Payment”) of the above mentioned Contract, ----- (name and address of Contractor) (hereinafter called “the Contractor”) shall deposit with----- (name of Employer) a bank guarantee his proper and faithful performance under the said Clause of the Contract in an amount of----- (amount of Guarantee)* - -----in words).

We, the----- (bank of financial institution), as instructed by the Contractor, agree unconditionally and irrevocably to guarantee as primary obligator and not as Surety merely, the payment to ----- (name of Employer) on his first demand without whatsoever right of obligation on our part and without his first claim to the Contractor, in the amount not exceeding --- ----- (amount of guarantee)* - ----- (in words)

We further agree that no change or addition to or other modifications of the terms of the Contractor or Works to be performed thereunder or of any of the Contract documents which may be made between ----- (name of Employer) and the Contractor, shall in any way release us from any liability under this guarantee, and we hereby waive notice of any such change, addition or modifications.

This guarantee shall remain valid and in full effect from the date of the advance payment under the Contract until ----- (name of employer) receives full repayment of the same amount from the contractor.

YOUR’S TRULY

Signature and Seal _____
Name of Bank/ Financial Institution _____
Address _____
Date _____

* An amount shall be inserted by that Bank or Financial Institution representing the amount of the Advance Payment, and denominated in Indian Rupees.

Letter of Acceptance
(Letter head paper of the Employer)

_____ (date)

To,

_____ (Name and address of the Contractor)

Dear Sirs,

This is to notify you that your Bid dated _____ for execution of the _____ (Name of the contract and identification number, as given in the Instructions to Bidders) for the Contract Price of Rupees _____ (_____) (amount in words and figures) as corrected and modified in accordance with the Instructions to Bidders* is hereby accepted by our organization.

You are requested to furnish performance security, in the form detailed in para 34.1 of ITB for an amount equivalent to Rs. _____ within **10 days** of the receipt of this letter of acceptance up to beyond **60 days** from the date of expiry of defects Liability period i.e. up to _____ and the Additional Performance Security for an amount equivalent to Rs. _____ shall be valid beyond 28 (twenty-eight) days of Project Completion Date i.e. up to _____ and sign the contract, failing which action as stated in Para 34.3 of ITB will be taken.

Yours Faithfully

Authorized Signature
Name and title of Signatory
Name of Employer

* Delete "Corrected and" or and modified if only one of these actions applies. Delete as corrected and modified in accordance with the Instructions to Bidders, if corrections or modifications have not been affected.

Issue of Notice to proceed with the work

(Letterhead of the Employer)

To, _____ (date)

_____ (Name and address of the Contractor)

Dear Sirs,

Pursuant to your furnishing the requisite security in ITB Clause 34.1 and signing of the Contract for the construction of _____

_____ at a bid Price of Rs.
_____.

You are hereby instructed to proceed with the execution of the said works in accordance with the contract documents.

Yours faithfully

(Signature, name and title of signatory authorized
To sign on behalf of Employer)

AGREEMENT FORM

This agreement, made on the _____ day of _____ between _____ (name and address of Employer) (Hereinafter called "the Employer) and _____ (name and address of contractor) hereinafter called "the Contractor" of the other part.

Whereas the Employer is desirous that the Contractor execute

Name and identification number of contract (hereinafter called "the works") and the employer has accepted the Bid by the Contractor for the execution and completion of such works and the remedying of any defects therein, at a cost of Rs.

NOW THIS AGREEMENT WITNESSETH AS FOLLOWS

1. In this Agreement, words and expression shall have the same meanings as are respectively assigned to them in the conditions of contract hereinafter referred to and they shall be deemed to form and be read construed as part of this Agreement.
2. In Consideration of the payment to be made by the Employer to the contractor as hereinafter mentioned, the Contractor hereby covenants with the Employer to executive and complete the works and remedy any defects therein in conformity in all aspects with the provisions of the contracts.
3. The employer hereby covenants to pay the Contractor in consideration of the execution and completion of the works and the remedying the defects wherein contract price or such other sum as may become payable under the provisions of the Contract at the times and in the manner prescribed by the contract.
4. The Following documents shall be deemed to form and be ready and construed as part of this Agreement viz
 - i) letter of Acceptance
 - ii) Notice to proceed with the works:
 - iii) Contractor's Bid

- iv) Conditions of contract: General and Special
- v) Contract Data
- vi) Additional conditions
- vii) Drawings
- viii) Bill of Quantities and
- ix) Any other documents listed in the Contract data as forming part of the Contract.

In witness whereof the parties there to have caused this Agreement to be executed the day and year first before written

The Common seal of _____

Was hereunto affixed in the presence of :

Signed, sealed and Delivered by the said _____

In the presence of

Binding signature of Employer _____

Binding Signature of Contractor _____

UNDERTAKING
(For Validity)

I, the undersigned do hereby undertake that our firm M/s
..... agree to abide by this bid for a period.....days for
date fixed for receiving the same and it shall be binding on us and may be accepted at any
time before the expiration of that period.

(Signed by an Authorized officer of the firm)

Title of officer

Name of firm

DATE

VOLUME-IV

SECTION - 9

DRAWINGS

Chain Link Fencing

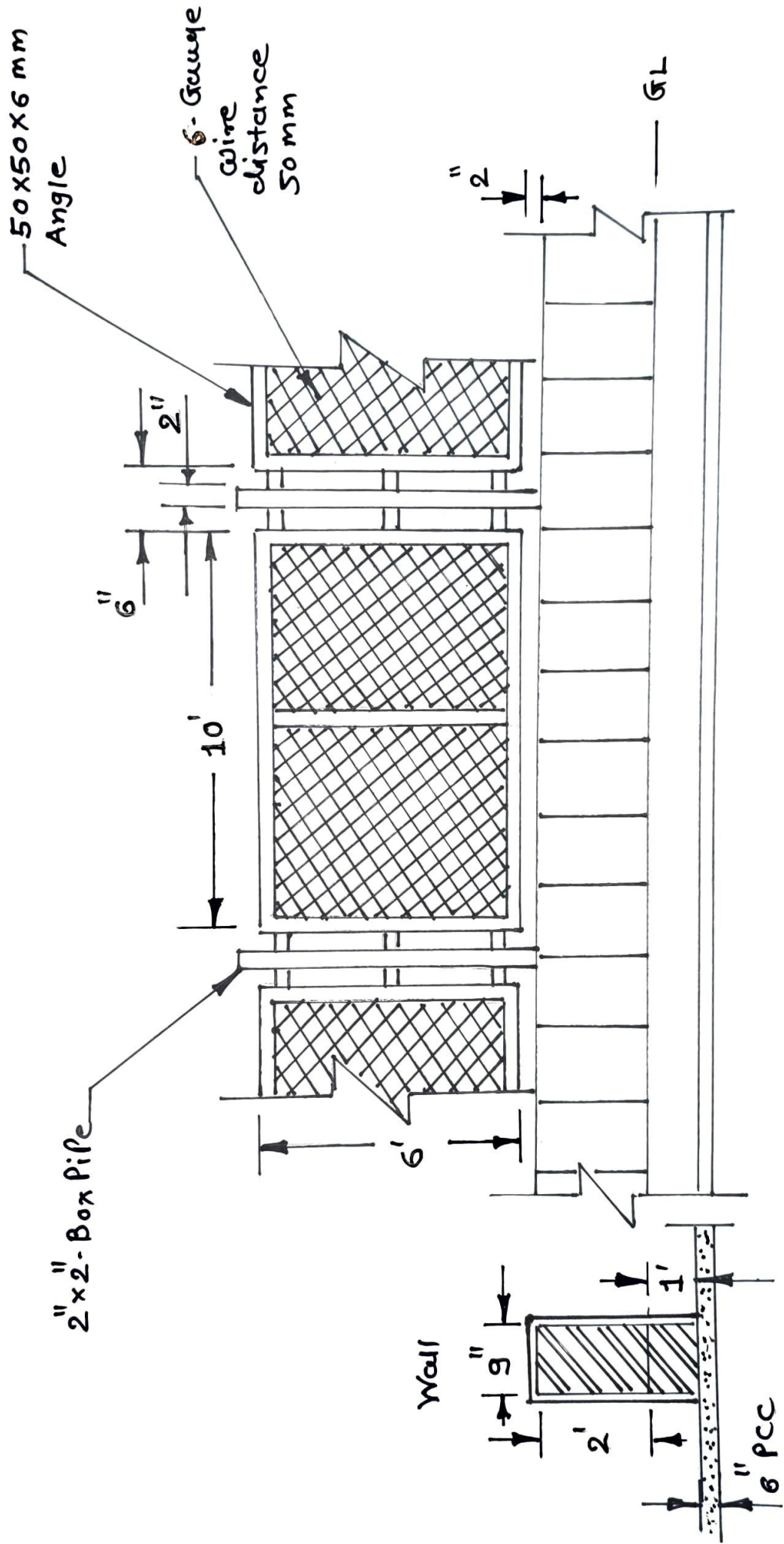

VOLUME-V

SECTION - 10

DOCUMENTS TO BE FURNISHED BY BIDDER

ANNEXURE-I

List of Documents required for the work (Online as well as Original physical Hard copy)

PART A- Preliminary Stage

COMPULSORY DOCUMENTS (Online as well as Physical)

1. Scanned copy of DD of Tender Fee (of amount as prescribed in tender notice)
2. Scanned copy of Bid Security / EMD Exemption Certificate as per Clause No.16 of Section-1 (b) (of amount as prescribed in tender notice).

Part B Technical Stage(Online as well as Physical)

3. Scanned copy of Valid Registration certificate/renewal receipt of registration fee (for those bidders who are registered in equivalent to class "B" and above)" of Gujarat State).

PART C Financial Bid (Online Only)

4. Form of Bid as prescribed in Volume-III, Section-6.
5. Bill of Quantities Volume-III, Section-7